

# Product Instructions



## Three Way Mixing Valve

Three way mixing valves regulate fluid temperature to the system from the heat source. These valves are ideal for mixing fluid to control temperature in heating, cooling, and snow ice melting applications. The valves can be controlled both manually or automatically with the use of actuator (Stock Code 20042)

### Features

- Compact and lightweight
- Versatile for numerous piping configurations
- Dezincification resistant brass (CW 602N)
- Simple adjustable scale indicating valve position
- Adjustable valve position scale

### Specifications

Fluid temperature limits: 14°F-230°F  
 Max operating pressure: 145 psi  
 Max differential pressure: 14.5 psi  
 Max glycol mixture: 50%  
 Materials: brass valve body (CW 602N)  
 PPS composite shaft and bushing EPDM O-Ring

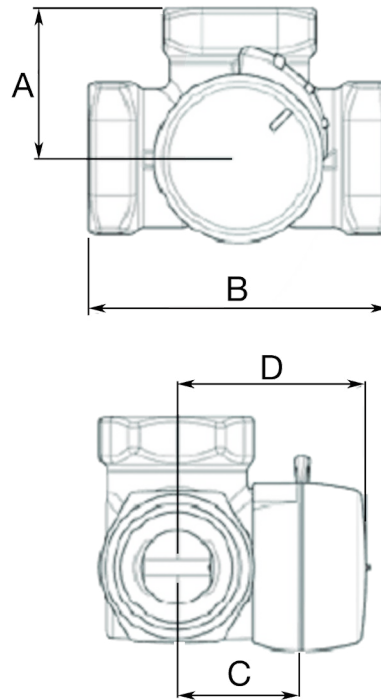

Stock Code	Size	Type	A (in)	B (in)	C (in)	D (in)	Weight (lbs)	CV Value	Flow (gpm)	Heat Capacity (BTU/H)	Pressure drop (psi)	Pressure Drop (ft of head)
20080	3/4"	NPT	1.42	2.83	1.26	1.97	0.95	7.3	5 7	50,000 70,000	0.7 1.0	1.6 2.2
20081	1"		1.61	3.23	1.34	1.54	1.54	11.7	12 17	120,000 170,000	1.0 2.1	2.4 4.8
20082	1-1/4"		1.85	3.70	1.46	2.09	2.09	18.7	19 24	190,000 240,000	1.0 1.6	2.3 3.7
20083	1-1/2"		2.09	4.17	1.73	3.7	3.7	29.3	29 34 38	290,000 340,000 380,000	1.0 1.2 1.7	2.2 2.7 3.8
20084	2"		2.36	4.72	1.81	5.07	5.07	46.8	47 53 59 65	470,000 530,000 590,000 650,000	1.0 1.2 1.3 1.9	2.3 2.9 2.9 4.4

Note: Heat capacity is based on water at a ΔT of 20°F. The fluid used to calculate pressure drop across the valve is water @ 100°F

**Viega... The global leader in plumbing, heating and pipe joining systems**

301 N. Main, 9th Floor • Wichita, KS 67202 • Ph: 800-976-9819 • Fax: 316-425-7618 • www.viega.com

©2011, ProPress®, FostaPEX®, Seapress®, MegaPress®, MegaPressG® and Viega® are registered trademarks of Viega GmbH & Co. PureFlow®, Smart Connect®, Climate Panel®, Climate Mat®, Climate Trak®, MANABLOC®, Radiant Wizard®, S-no-Ice®, Snap Panel®, XL® and XL-C® are registered trademarks of Viega LLC. MiniBloc®, ProRadiant®, PolyAlloy®, SmartLoop® and Zero Lead® are trademarks of Viega LLC; GeoFusion®, ProPressG® and ViegaPEX® are trademarks of Viega GmbH & Co. KG.

# Product Instructions

viEGA

**Scenario 1 Wiring and Piping: Boiler Loop on left, System Supply on right, System Return into branch**

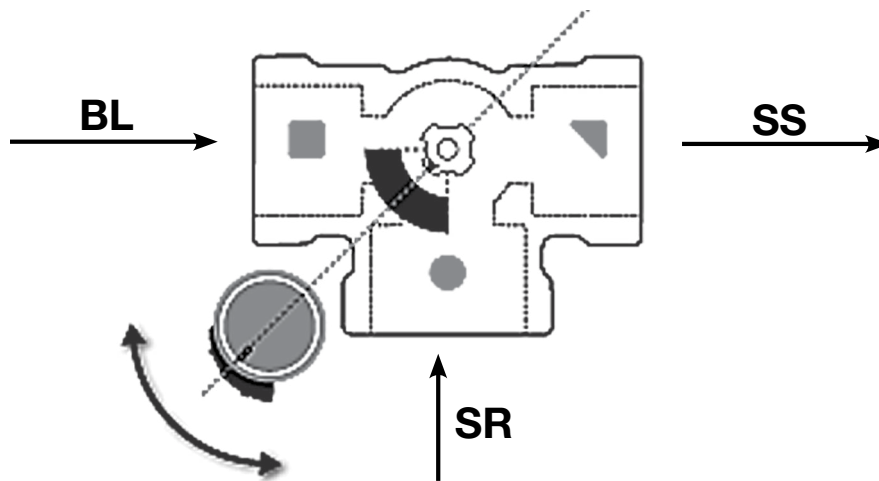

**Scenario 2 Wiring and Piping: Boiler Loop on right, System Supply on left, System Return into branch**

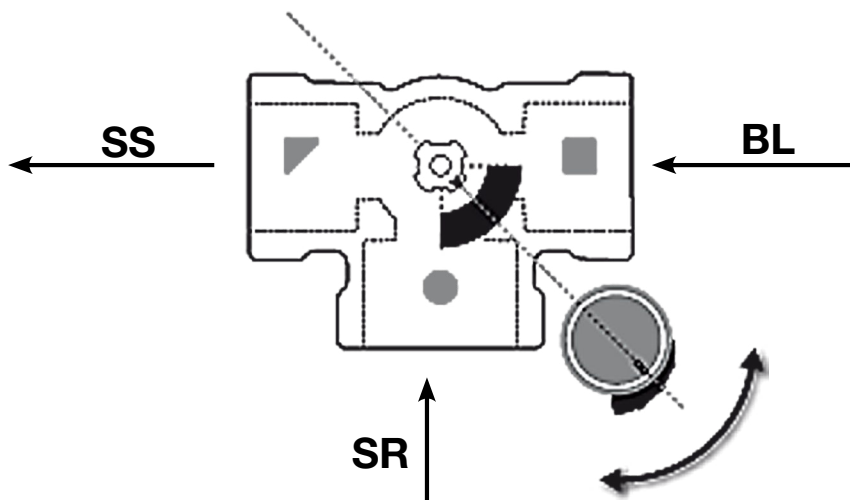

**NOTE: For precise temperature control it is imperative that the initial position of the valve used is half open. This can be accomplished by positioning the groove of the white plastic adapter between Boiler Supply and Boiler Return. The actuator itself can be mounted onto the valve in any position.**

**ViEga... The global leader in plumbing, heating and pipe joining systems**

301 N. Main, 9th Floor • Wichita, KS 67202 • Ph: 800-976-9819 • Fax: 316-425-7618 • [www.viega.com](http://www.viega.com)

©2011, ProPress®, FostaPEX®, Seapress®, MegaPress®, MegaPressG® and ViEga® are registered trademarks of ViEga GmbH & Co. PureFlow®, Smart Connect®, Climate Panel®, Climate Mat®, Climate Trak®, MANABLOC®, Radiant Wizard®, S-no-Ice®, Snap Panel®, XL® and XL-C® are registered trademarks of ViEga LLC. MiniBloc®, ProRadiant®, PolyAlloy®, SmartLoop® and Zero Lead® are trademarks of ViEga LLC; GeoFusion®, ProPressG® and ViEgaPEX® are trademarks of ViEga GmbH & Co. KG.

# Product Instructions



## Piping Schematic of Basic Heating Control with Three Way Mixing Valve and 3 Manifolds in Parallel

LEGEND: 4-way Mixing Valve and Motor	
	4-way Mixing Valve and Motor
	Spring check
	Circulator
	Draw Off (Purge Valve)
	Make-Up Water
	Pressure Differential Bypass Valve
	Stainless Manifold w/ Flow Gauges
	Baseboard Zone (S)
	Diaphragm-Type Expansion Tank
	Zone Valve

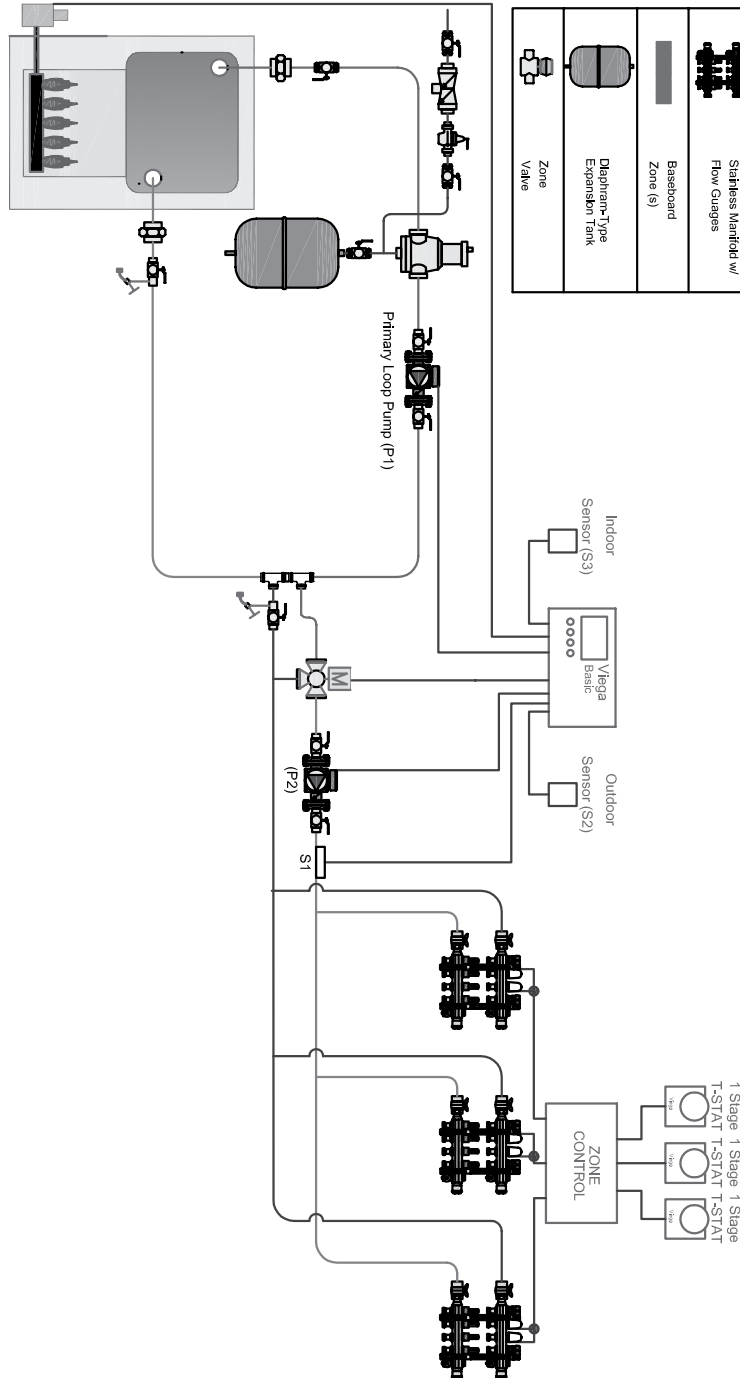

### NOTES: Piping

1. This drawing shows system piping concept only. Installer is responsible for all equipment & detailing required by local codes.
2. Size header piping for maximum flow velocity of 2 ft. / sec.
3. All other piping should be sized for a maximum flow velocity of 4 ft. / sec.
4. Install a minimum of 12 diameters of straight pipe upstream of all circulators and check valves.
5. Install isolating flanges or isolating valves on all circulators.
6. Install purging valve(s) on all circuits.
7. All closely spaced tees shall be within 4 pipe diameter center to center spacing.
8. Install minimum of 6 pipe diameters of straight pipe upstream and downstream of all closely spaced tees.
9. Differential pressure bypass valve prevents flow noise under partial load conditions (some zone valves closed).
10. Set differential pressure bypass valve to delta P of distribution system with all zones open + 1 psi
11. Not all components may be required depending on control strategy (i.e. constant circulation).

**Viega... The global leader in plumbing, heating and pipe joining systems**

301 N. Main, 9th Floor • Wichita, KS 67202 • Ph: 800-976-9819 • Fax: 316-425-7618 • www.viega.com

©2011, ProPress®, FostaPEX®, Seapress®, MegaPress®, MegaPressG® and Viega® are registered trademarks of Viega GmbH & Co. PureFlow®, Smart Connect®, Climate Panel®, Climate Mat®, Climate Trak®, MANABLOC®, Radiant Wizard®, S-no-Ice®, Snap Panel®, XL® and XL-C® are registered trademarks of Viega LLC. MiniBloc®, ProRadiant®, PolyAlloy®, SmartLoop® and Zero Lead® are trademarks of Viega LLC; GeoFusion™, ProPressG™ and ViegaPEX™ are trademarks of Viega GmbH & Co. KG.

# Product Instructions



## Wiring Schematic of Basic Heating Control with Three Way Mixing Valve and 3 Manifolds in Parallel

- NOTES: Wiring**
1. This drawing shows system wiring concept only installer is responsible for all equipment & detailing required by local codes.
  2. All wiring shall be in conformance with the latest edition of the National Electrical Code.
  3. Maximum current rating of Basic and Advance Heating Control Relay is 10 Amps. Basic and Advance Snow Melting Control Relay is 5 Amps, Maximum current rating of Zone Control Relays is 5 Amps, if circulator draw exceeds this use pilot relay with 120 VAC coil operated by Viega Control.
  4. Consult with control / boiler manufacturer for limitations and installation instructions
  5. Do not run the wires parallel to telephone or power cables. If the sensor wires are located in an area with strong source of electromagnetic interference (EMI), shielded cable or twisted pair should be used or the wires can be run in a grounded metal conduit. If using shielded cable, the shield wire should be connected to the Com or Com Sen terminal on the control and not to earth ground. Use 18 AWG copper wiring for all sensor wiring. Sensors should be located 12" down stream of mixing point.
  6. DHW priority relay must be rated to handle full amperage load of zone circulator relay center.
  7. Other configurations are possible, but all space heating zone circulators must turn off when DHW mode is on or heat source needs to be sized for multiple loads.

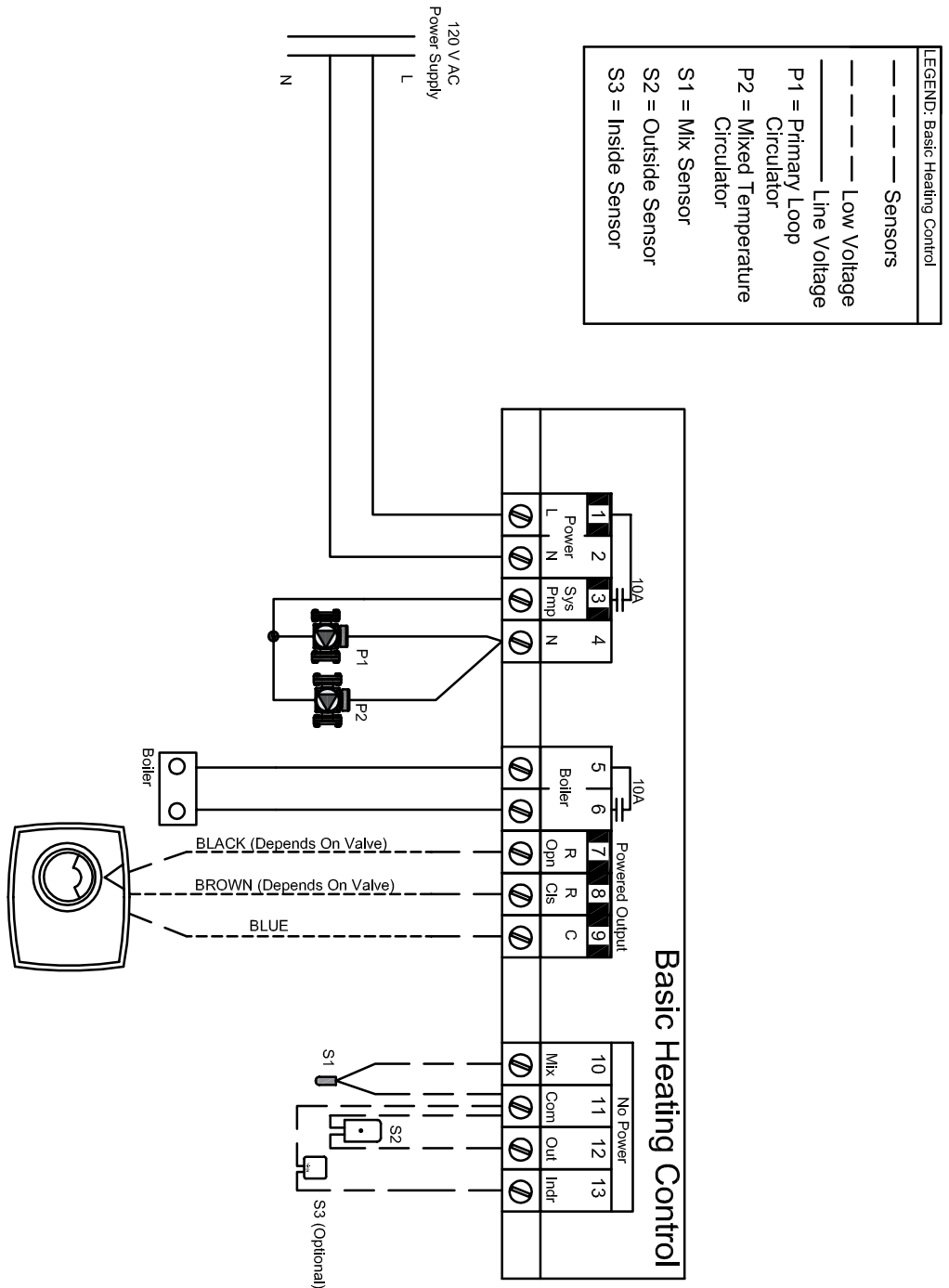

**Viega... The global leader in plumbing, heating and pipe joining systems**

301 N. Main, 9th Floor • Wichita, KS 67202 • Ph: 800-976-9819 • Fax: 316-425-7618 • www.viega.com

©2011, ProPress®, FostaPEX®, Seapress®, MegaPress®, MegaPressG® and Viega® are registered trademarks of Viega GmbH & Co. PureFlow®, Smart Connect®, Climate Panel®, Climate Mat®, Climate Trak®, MANABLOC®, Radiant Wizard®, S-no-ice®, Snap Panel®, XL® and XL-C® are registered trademarks of Viega LLC. MiniBloc®, ProRadiant®, PolyAlloy®, SmartLoop® and Zero Lead® are trademarks of Viega LLC; GeoFusion™, ProPressG™ and ViegaPEX™ are trademarks of Viega GmbH & Co. KG.