

Product Instructions

viiega

System Pressurization Kit

Applications

The Viega System Pressurization Kit provides the installer with the ability to pressurize with air or water and monitor a radiant system during installation or troubleshooting.

Features

Fits brass manifolds, stainless manifolds, injection stations or tubing alone. Easily adaptable to any diameter of PEX tubing (or even copper) using SVC adapters (sold separately).

Specifications

- Connects to male hose thread (GHT / NH) or SVC connection (with included adapter)
- Schraeder valve for air pressurization
- 0 to 100 psi gauge
- Brass fittings

Operations

During concrete pours and when the finish floor is installed the radiant system must be pressure tested. Check local codes for compliance or additional test requirements.

1. Double check all connections to ensure proper seal.
2. Connect System Pressurization Kit to any purge valve (or to tubing when manifolds are not yet installed).
3. Pressurize system to 80 psi to detect any leaks.
4. The system should hold 80 psi for a minimum of 24 hours.
5. Maintain and monitor pressure during pouring of concrete and installation of finish floor to simplify leak detection.

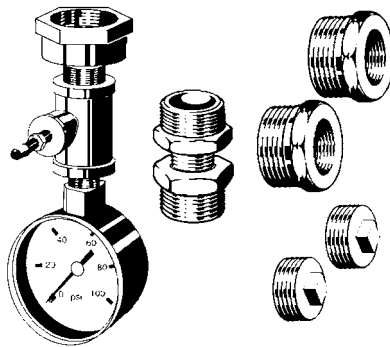

Installation

System Pressurization Kit connects in two ways:

- Kit connects directly to a purge valve on the brass manifold accessory kit or to purge valve on the stainless manifold or injection station. Remove air vent, but leave

check valve attached to end cap. When manifolds are being pressure tested without an Injection Station or prior to boiler piping, brass manifold ends may be capped with 1" NPT plugs (included), or if stainless manifolds are being used, you may plug the 1-1/4" union ends with included 1-1/4" x 1" reducers attached to 1" NPT plugs.

- For jobs where manifolds have not yet been installed, tubing may be pressurized directly. Screw hose x SVC adapter piece (included) into the female hose thread of the pressurization kit, and then insert any SVC tubing adapter (sold separately). For multiple circuits of tubing, temporarily connect all circuits together with couplings, plug one end, and attach pressurization kit to other end.

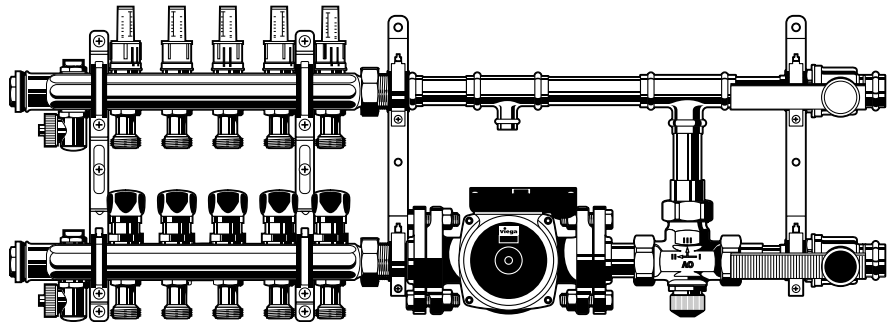

Any SVC fitting (compression PEX, press PEX, or press copper)

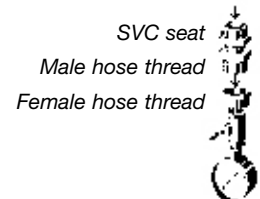

Viega... The global leader in plumbing, heating and pipe joining systems

301 N. Main, 9th Floor • Wichita, KS 67202 • Ph: 800-976-9819 • Fax: 316-425-7618 • www.viega.com

©2011, ProPress®, FostaPEX®, Seapress®, MegaPress®, MegaPressG® and Viega® are registered trademarks of Viega GmbH & Co. PureFlow®, Smart Connect®, Climate Panel®, Climate Mat®, Climate Trak®, MANABLOC®, Radiant Wizard®, S-no-Ice®, Snap Panel®, XL® and XL-C® are registered trademarks of Viega LLC. MiniBloc™, ProRadiant™, PolyAlloy™, SmartLoop™ and Zero Lead™ are trademarks of Viega LLC; GeoFusion™, ProPressG™ and ViegaPEX™ are trademarks of Viega GmbH & Co. KG.

PI-PR-561141 0212 (System Pressurization Kit)