

Product Instructions

viega

Stainless Manifold Shut Off/Balancing

Stainless manifold is to be used in closed loop hydronic heating, cooling and snow melting systems. These preassembled 1-1/4" diameter stainless supply and return manifolds come attached to two 6-5/8" spacing brackets for compact remote mounting. This stainless manifold provides shut off and balancing valves for each circuit. Manifolds used with flow rates up to 2 gpm per circuit, maximum of 18 gpm per manifold. The air bleeder and purge valve are connected and factory tested. 1-1/4" Union connection, 1" NPT removable end caps. SVC Circuit connection fittings are sold separately.

Dimensions	
Height	12.1"
Depth	3.6"
Manifold	Total Width
2 outlets	8.21"
3 outlets	10.2"
4 outlets	12.2"
5 outlets	14.1"
6 outlets	16.1"
7 outlets	18.1"
8 outlets	20.0"
9 outlets	22.0"
10 outlets	24.0"
11 outlets	25.9"
12 outlets	27.9"

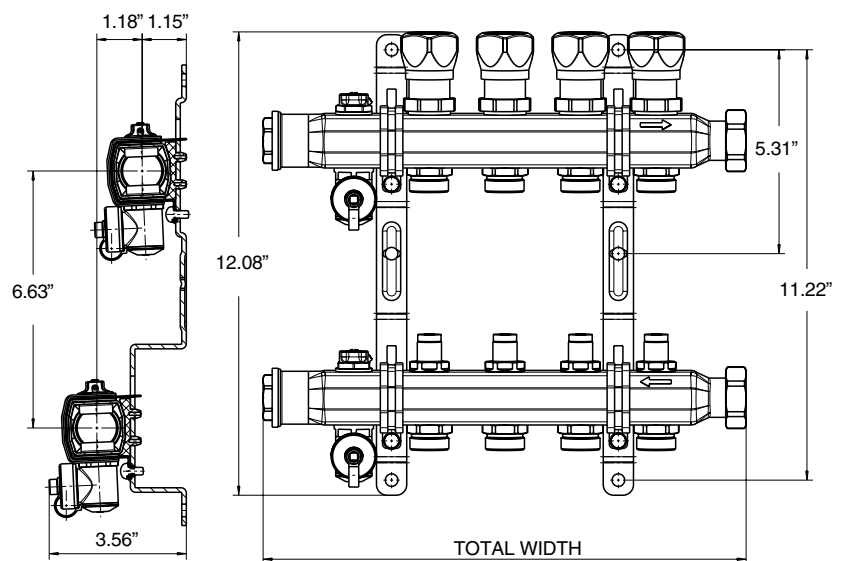

*When extending the manifold, Viega requires using thread sealant paste on the 1" NPT manifold end connection.

Technical Data

- 1-1/4" 304 Stainless Header Stock
- Supply Manifold with Balancing valve/flow meter
- Return Manifold with shut off valves (blue caps)
- Factory installed air bleeders and purge valves
- Mounting Brackets
- Max. operating temperature: 180°F
Short periods of 200°F
- Max. operating pressure: 100 psi

The return header is fitted with shut off valves which are suitable to receive optional 24V powerheads for control over each circuit via thermostat.

Note: Use new style white cap powerheads with this manifold (stock code #15061 2 wire powerheads stock code #15064 4 wire powerheads).

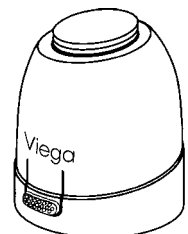

Viega... The global leader in plumbing, heating and pipe joining systems

301 N. Main, 9th Floor • Wichita, KS 67202 • Ph: 800-976-9819 • Fax: 316-425-7618 • www.viega.com

©2012, ProPress®, FostaPEX®, GeoFusion®, Seapress® MegaPress®, MegaPressG®, and Viega® are registered trademarks of Viega GmbH & Co. PureFlow®, Smart Connect®, Climate Panel®, Climate Mat®, Climate Trak®, MANABLOC®, Radiant Wizard®, S-no-Ice®, Snap Panel®, XL® and XL-C® are registered trademarks of Viega LLC. MiniBloc™, Rapid Grid™, ProRadiant™, PolyAlloy™, SmartLoop™ and Zero Lead™ are trademarks of Viega LLC; ProPressG™ and ViegaPEX™ are trademarks of Viega GmbH & Co. KG. RIDGID® is a registered trademark of RIDGID, Inc.

Product Instructions

viega

Operation

End Connections

1. Use only Viega's manifold adapters to connect manifold.
2. Make sure that EPDM sealing element is placed in union connection for proper seal.
3. DO NOT use teflon tape or thread sealant paste on union connection.
4. When extending the manifold, Viega requires using thread sealant paste on the 1" NPT manifold end connection.

Circuit connection configuration

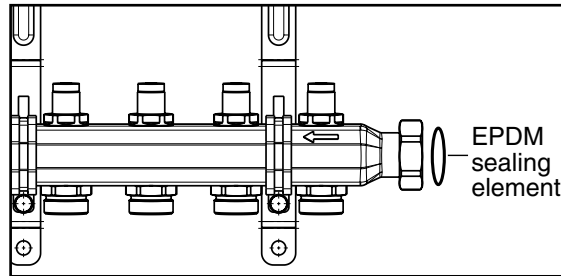

SVC Compression Pex Adapters attach PEX tubing to manifolds.



SVC Compression Copper Adapters connect 1/2" and 3/4" copper tubing to SVC seat without soldering.



SVC Press Adapters allow the Viega press connection system to be used on manifolds.

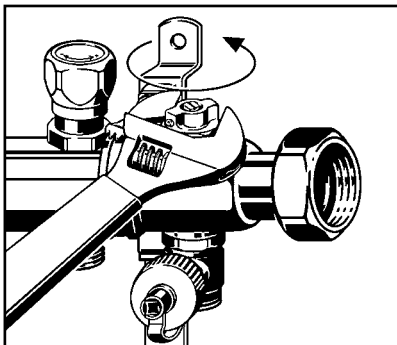

1. Remove air bleeder.

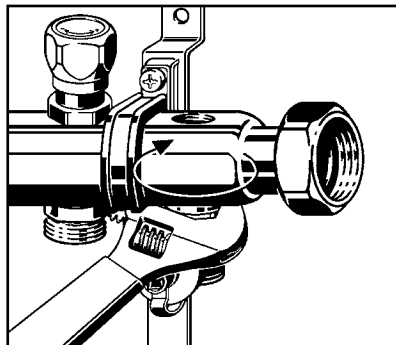

2. Remove purge valve.

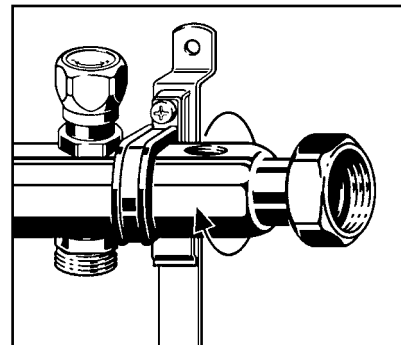

3. Flip manifold stock over.

Some applications will require the tubing to be brought to the manifold from above. In this type of situation, the purge valve and air bleeder will need to be switched along with flipping the manifold stock over.

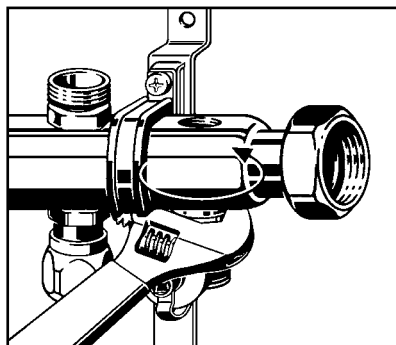

4. Attach purge valve.

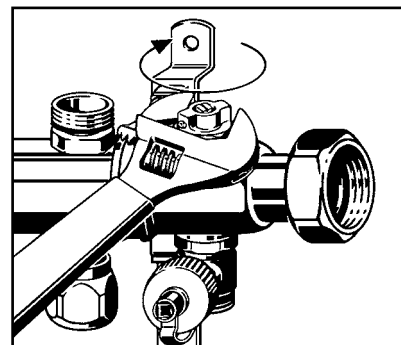

5. Attach air bleeder

Viega... The global leader in plumbing, heating and pipe joining systems

301 N. Main, 9th Floor • Wichita, KS 67202 • Ph: 800-976-9819 • Fax: 316-425-7618 • www.viega.com

©2012, ProPress®, FostaPEX®, GeoFusion®, Seapress® MegaPress®, MegaPressG®, and Viega® are registered trademarks of Viega GmbH & Co. PureFlow®, Smart Connect®, Climate Panel®, Climate Mat®, Climate Trak®, MANABLOC®, Radiant Wizard®, S-no-Ice®, Snap Panel®, XL® and XL-C® are registered trademarks of Viega LLC. MiniBloc™, Rapid Grid™, ProRadiant™, PolyAlloy™, SmartLoop™ and Zero Lead™ are trademarks of Viega LLC; ProPressG™ and ViegaPEX™ are trademarks of Viega GmbH & Co. KG. RIDGID® is a registered trademark of RIDGID, Inc.

Product Instructions

viega

Pressure Testing

Before the finish floor is installed and during concrete pouring the radiant system must be pressure tested. Air or water may be used as the medium.

The following procedure is recommended by Viega. Check the local building codes for compliance or additional test requirements.

NOTE: If the tubing is damaged, repair punctured section with a compression coupling.

Procedure:

1. Double check all connections to manifold to ensure proper seal.
2. Connect manifold pressurization kit (1) to any purge valve (2).
3. Pressurize the system to 100 psi to detect potential nail or screw penetrations.
4. The system should hold the 100 psi for a minimum of 1 hour.

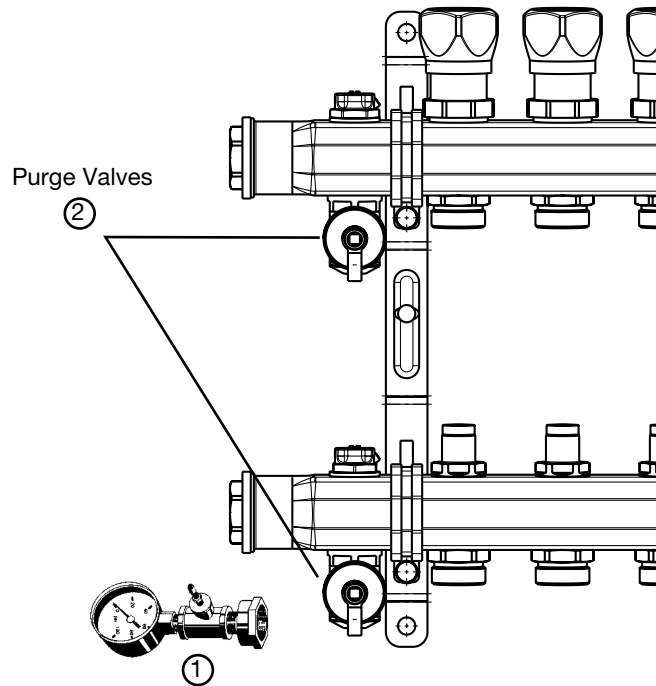

Purging

1. Attach drain hose to purge valve hose connection on return header and open valve with valve cap.
2. Close all but one balancing valve on supply header using a 5 mm allen wrench or included valve key (reference steps on page 4). Close isolation ball valve on boiler return line if mixing station is attached. Remove plastic dust cap or temperature controller from 3-way valve, and make sure that high limit kit is fully open (refer to mixing station product instructions).
3. Open boiler fast fill valve to purge circuit. After purging first circuit, close valve and open next one. Continue with one circuit at a time until all circuits have been purged.
4. Close purge valve and open all balancing and boiler valves. If mixing station is attached, reset high-limit kit, and reinstall temperature controller or actuator onto 3-way valve.
5. Any remaining air pockets in the system will be eliminated through the boiler's automatic air vent after a few hours of constant circulation.

NOTE: If the system must be purged again in the future for any reason, the high limit kit must be reopened during purging for full flow.

Viega... The global leader in plumbing, heating and pipe joining systems

301 N. Main, 9th Floor • Wichita, KS 67202 • Ph: 800-976-9819 • Fax: 316-425-7618 • www.viega.com

©2012, ProPress®, FostaPEX®, GeoFusion®, Seapress® MegaPress®, MegaPressG®, and Viega® are registered trademarks of Viega GmbH & Co. PureFlow®, Smart Connect®, Climate Panel®, Climate Mat®, Climate Trak®, MANABLOC®, Radiant Wizard®, S-no-Ice®, Snap Panel®, XL® and XL-C® are registered trademarks of Viega LLC. MiniBloc™, Rapid Grid™, ProRadiant™, PolyAlloy™, SmartLoop™ and Zero Lead™ are trademarks of Viega LLC; ProPressG™ and ViegaPEX™ are trademarks of Viega GmbH & Co. KG. RIDGID® is a registered trademark of RIDGID, Inc.

Product Instructions

viEGA

Initial Balancing

System should be properly purged before balancing is done. Many times it is not possible to design the system using equal circuit lengths, so the system must be balanced in order to ensure proper flow to each circuit on the manifold.

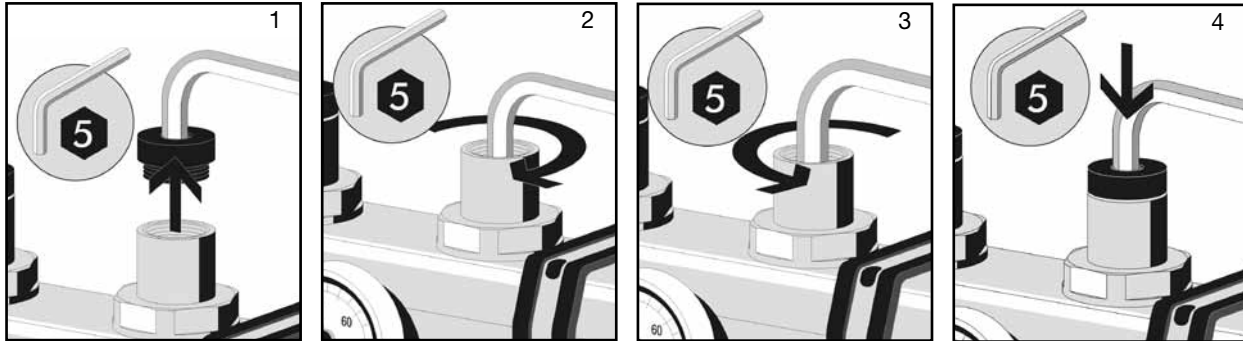

Procedure (To begin balancing, all circuits must be in the closed position):

1. Use a 5 mm allen wrench (or included valve key) to remove black cap by turning counterclockwise.
2. Once black cap is removed, use allen wrench or key to close valve completely by turning clockwise.
3. To begin flow, turn allen wrench counterclockwise until desired flow is met.
4. Reattach black cap.

Note: Valve will go from fully closed to fully opened in approximately 5-1/2 turns.

ViEGA... The global leader in plumbing, heating and pipe joining systems

301 N. Main, 9th Floor • Wichita, KS 67202 • Ph: 800-976-9819 • Fax: 316-425-7618 • www.viega.com

©2012, ProPress®, FostaPEX®, GeoFusion®, Seapress® MegaPress®, MegaPressG®, and ViEGA® are registered trademarks of ViEGA GmbH & Co. PureFlow®, Smart Connect®, Climate Panel®, Climate Mat®, Climate Trak®, MANABLOC®, Radiant Wizard®, S-no-Ice®, Snap Panel®, XL® and XL-C® are registered trademarks of ViEGA LLC. MiniBloc™, Rapid Grid™, ProRadiant™, PolyAlloy™, SmartLoop™ and Zero Lead™ are trademarks of ViEGA LLC; ProPressG™ and ViEGAPEX™ are trademarks of ViEGA GmbH & Co. KG. RIDGID® is a registered trademark of RIDGID, Inc.