



Viega... The global leader in plumbing and heating systems.

S-no-Ice[®] Snow Melting System



Installation Manual

CONTENTS

1	System Advantages/Benefits		Appendix A	
	1.1 Snow Melting Advantages	4	Pressure Drop Charts	30
	1.2 Application Benefits	4	Appendix B	
	1.3 Basic Snow Melt Control Benefits	5	Annual Operating Data	36
	1.4 Advanced Snow Melt Control Benefits	5	Appendix C	
			Stairs and Slopes (Drainage)	37
2	System Design		Appendix D	
	2.1 Selecting Level for Design Criteria	6	Penetrating Joints	38
	2.2 Calculating the Snow Melting Load	7	Appendix E	
	2.3 Calculating the Tube Spacing	9	Making a Compression Connection	39
	2.4 Calculating the Fluid Supply Temperature	9	Appendix F	
	2.5 Calculating the Amount of Tubing and Fasteners	10	Making a Press Connection	41
	2.6 Water/ Glycol Mixture	11	Appendix G	
	2.7 Calculating the Flow Rate	13	Sizing the Mixing Valve	42
	2.8 Calculating the Pressure Drop	14	Appendix H	
	2.9 Selecting the Pump	15	Making a Material List	43
	2.10 Approximating the Operating Cost	15		
	2.11 Selecting the Heat Exchanger	16		
3	Snow Melting System Installation			
	3.1 Thermal Mass	16		
	3.2 Typical Cross Sections	17		
	3.3 Selecting the Control Package	21		
	3.4 Schematics - Piping and Controls	22		
	3.5 Layout Planning	24		
	3.6 Installing the Tubing	26		
4	System Startup			
	4.1 Pressure Testing	29		
	4.2 Filling and Purging the System	29		

1.1 Snow Melting Advantages:

- Safety (Insurance)
- Solves snow removal problems in critical areas (stairs, slopes, intersections, ramps, pavers)
- Reduced maintenance
- Prevents salt and other chemicals from entering the building
- Extends slab life
- May utilize wasted energy



Figure 1.1



1.2 Application Benefits:



Figure 1.2A

Residential:

Snow melting in residential applications has gained widespread acceptance. A snow melting system can alleviate shoveling, plowing, sanding and salting. Typical application areas are driveways, walkways, patios and steps.

Commercial:

Snow melting in commercial applications reduces liability and improves accessibility. Clean sidewalks will attract customers and provide safety. Excellent choice under pavers (chemical melt aids, plowing, shoveling are difficult due to joints). Typical application areas are building entrances, parking ramps and lots.



Figure 1.2B

Industrial:

Snow melting in industrial applications is used where safe, clean and easy access is critical. Typical application areas are hospital emergency entrances, helipads, loading docks, and building entrances.



Figure 1.2C

1.3 Basic Snow Melt Control Benefits:

Features include:

- Automatic snow melt activation
- Slab high limit
- Senses air temperature
- Senses falling snow
- Timer switch for manual override activation

Application:

The Basic Snow Melt Control is typically used in small to medium size residential areas, driveways, walkways, patios, and steps.

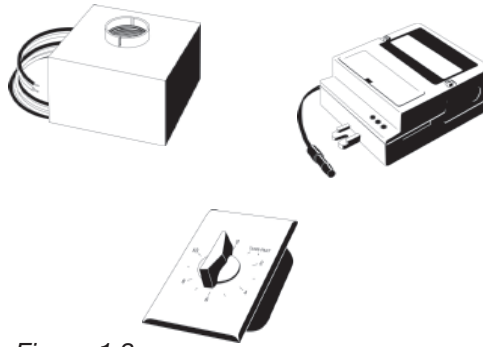

Figure 1.3

Note:

Snow sensor is located outside of slab in landscape area, on side of building or on roof.

1.4 Advanced Snow Melt Control Benefits:

Features include:

- Accurate and sensitive snow detection and system activation
- Slab idling capability
- Adjustable post purge cycle
- Durable sensors
- Monitors slab moisture and temperature
- Microprocessor control
- User-friendly adjustments
- LCD readout of sensors

Application:

The Advanced Snow Melt Control is typically used in medium to large size residential, commercial and industrial areas, building entrances, parking ramps and lots, emergency entrances. Use this control when accurate ice and snow detection is required. Ensures energy savings of up to 80% compared to thermostatically controlled systems.

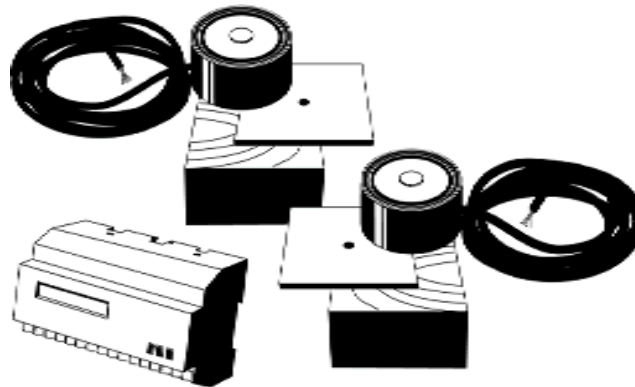

Figure 1.4

Note:

Snow and ice sensors are located within the heated slab (refer to product instructions supplied with the Advanced Snow Melt Control for detailed sensor installation).

2.1 Selecting Level for Design Criteria:

Define customer's intention and expectation of the snow melting system to select the correct design criteria level.

Levels:

- Level 1 Residential
- Level 2 Residential/Commercial
- Level 3 Industrial/Critical



Figure 2.1A
Residential driveway

Level 1

- Designed to keep the surface completely free of snow 95% of the time
- Occasional snow or ice buildup may occur
- Typically 5/8" Pextron tubing with 9" spacing (1/2" for small areas)

Common applications:

- Residential applications
- Driveways
- Sidewalks
- Hot tub areas



Figure 2.1B
Office building
(Digital)

Level 2

- Designed to keep the surface completely free of snow 98% of the time
- Typical level selection for most cases
- Typically 5/8" Pextron tubing with 6" or 9" spacing (3/4" for large areas)

Common applications:

- Commercial and light commercial applications
- Public access areas to buildings
- Handicapped ramps
- Commercial stairways



Figure 2.1C
Hospital Helipad

Level 3

- Designed to keep the surface completely free of snow 99% of the time
- Advanced Snow Melt Control for sensitivity
- System must melt snow with no accumulation
- Typically 5/8" Pextron tubing with 6" spacing (3/4" for large areas)
- System idling often needed for quick response

Common applications:

- Critical applications
- Hospital emergency ramps
- Helipads
- Access areas for emergency vehicles (fire stations, etc.)
- Areas deemed critical for public safety

SYSTEM DESIGN - CHAPTER 2

2.2 Calculating the Snow Melting Load:

Use the table at the right to find the heat output requirement. These values do not include back and edge heat losses; they must be added to get final heat output requirement (refer to back loss table 2.2B on page 15).

Procedure:

1. Find the location of the snow melting system in the first column.
2. Follow to the right and read the snow melting load under the column representing the appropriate level (refer to 3.1 for level selection).

Example:

City: Boston, MA

Level: 2

Snow melting load: 202 Btu/ h*ft²

Note:

See table 3.3B to calculate back and edge heat loss.

Output Requirements Btu/h *ft ²			
City	Level I	Level II	Level III
Albany, NY	140	187	212
Albuquerque, NM	188	191	242
Anaheim, CA	188	212	238
Bellingham, WA	137	212	237
Blainville, ND	281	215	307
Boise, ID	100	128	148
Bozeman, MT	185	202	229
Burlington, VT	210	277	320
Burlington, VT	154	184	200
Cheyenne, WY	201	229	261
Chicago, IL O'Hare INTL AP	158	188	238
Cleveland, OH	157	195	230
Colorado Springs, CO	187	202	219
Columbus, OH INTL AP	128	140	175
Des Moines, IA	208	235	230
Detroit, MI Metro	158	192	212
Duluth, MN	201	238	250
Elizabethtown, KY	118	134	162
Eugene, OR	130	185	171
Fairbanks, AK	144	174	202
Baltimore, MD BWI AP	172	235	232
Great Falls, MT	198	238	278
Indianapolis, IN	158	194	215
Lexington, KY	128	150	170
Madison, WI	184	208	248
Memphis, TN	172	200	208
Minneapolis, MN	184	198	207
Minneapolis-St. Paul, MN	198	229	254
New York, NY JFK AP	184	207	232
Oklahoma City, OK	215	248	260
Omaha, NE	130	222	250
Peoria, IL	188	201	227
Philadelphia, PA INTL AP	154	208	248
Pittsburgh, PA INTL AP	150	194	219
Portland, ME	195	234	268
Portland, OR	102	177	230
Rapid City, SD	252	312	351
Reno, NV	89	118	137
Salt Lake City, UT	89	110	120
Sault Ste. Marie, MI	188	218	240
Seattle, WA	138	171	206
Spokane, WA	118	148	150
Springfield, MO	179	215	234
St. Louis, MO INTL AP	170	198	227
Topoka, KS	192	234	246
Wichita, KS	200	248	238

Table 2.2A

Copyright 2003, American Society of Heating, Refrigerating and Air-Conditioning Engineers, Inc. www.ashrae.org.
 Reprinted by permission from ASHRAE 2003 Handbook-HVAC Applications.

Back and Edge Heat Loss

Back and edge heat loss is the percentage of heat lost through the back and edge of the snow melt area. Back and edge heat losses may add up to 40% to the snow melting load, depending on:

- Construction
- Insulation
- Exposure
- Operating temperature
- Ground temperature

Use this table to calculate the back and edge heat loss.

Back and Edge Heat Loss*	
Application	% Increase Multiplier
Full Below and Edge Insulation	0%
Full Below but No Edge Insulation	4% (1.04)
Perimeter and Edge Insulation	10% (1.10)
No Insulation	20% (1.20)
Exposed Bridge or Parking Ramp	40% (1.40)

Table 2.2B

* Tubing 2" below surface

Procedure:

1. Use back and edge heat loss table to find the multiplier (based on the application).
2. Multiply the snow melting load (from table 3.2A) by the multiplier to calculate the actual snow melting load.

Example:

Application:

Full below but no edge insulation

% Increase multiplier: 4%(1.04)

Actual snow melting load:

$$202 \text{ Btu/ h*ft}^2 \times 1.04 = \sim 210 \text{ Btu/ h*ft}^2$$

2.3 Calculating the Tube Spacing:

Decreasing the tube spacing will allow the snow melting system to operate at lower fluid temperatures while meeting the heat output requirements. Use table 2.3 to the right to calculate the proper tube spacing.

Procedure:

1. Find the tube size in the first column.
2. Follow to the right and read the recommended tube spacing under the column representing the heat load.

Example:

Tube size: 5/8"

Snow melting load: 200 Btu/h*ft²

Recommended tube spacing: 9"

		Recommended Tube Spacing in Concrete				
		Snow Melting Load (Btu/h*ft ²)				
Tube Size	Max. Circuit Length	100	150	200	250	300
1/2"	150 ft	9"	9"	6"	6"	6"
5/8"	250 ft	9"	9"	9"	6"	6"
3/4"	400 ft	12"	12"	9"	9"	6"

Table 2.3

Notes:

- Space tubing 1 inch closer for each inch of concrete cover over 2 inches.
- Space tubing 2 inches closer for each additional inch of pavers > 2-3/8" pavers.
- Space tubing 1 inch closer for asphalt applications.

2.4 Calculating the Fluid Supply Temperature:

Use table 2.4 to calculate the fluid (antifreeze solution) supply temperature.

Procedure:

1. Find the snow melting load in the first column.
2. Follow to the right and read the recommended fluid supply temperature under the column representing the selected tube spacing.

Example:

Snow melting load: 200 Btu/h*ft²

Tube spacing: 9 inches

Fluid supply temperature: 131°F

Snow Melting Load (Btu/h*ft ²)	Fluid Supply Temperature (°F)*		
	Tube Spacing (inches)		
	6	9	12
100	100	100	103
150	100	106	128
200	108	131	153
250	133	156	
300	158		

Table 2.4

* Based on a 30 F° temperature drop

Note:

Fluid supply temperature of 130°F is typical for snow melting applications.

2.5 Calculating the Amount of Tubing and Fasteners:

- Calculate the snow melt area.
- Use this chart to make an initial material list for the amount of tubing and fasteners needed.

Note: This estimation does not include controls. For complete worksheet see Appendix H.

Equation:
 Snow Melt Area x Multiplier =
 Estimated amount

Tubing (1/2" 5/8" 3/4")	Snow Melt Area (ft ²)	Multiplier	Estimated Amount
6" Spacing		2.2	
9" Spacing		1.5	
12" Spacing		1.1	

Table 2E

Fasteners*	Snow Melt Area (ft ²)	Multiplier	Estimated Amount
6" Spacing		1.1	
9" Spacing		.75	
12" Spacing		.55	

Table 2.5A

- Use this snow melt area accompanied with the chart to practice estimating -

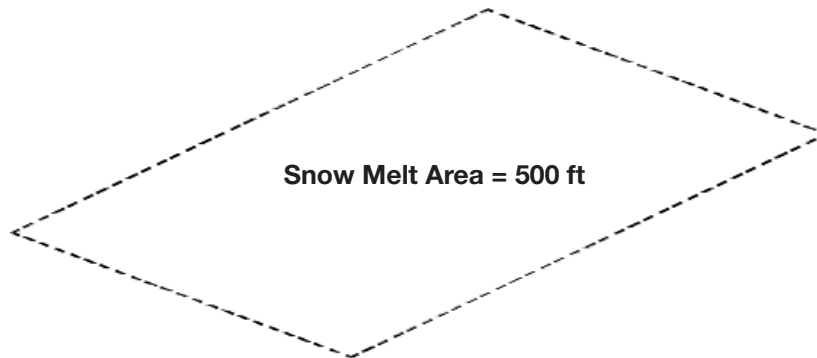

Figure 2.5

Solutions:

Remember this table is only for estimating. The number of circuits in the area will be covered in section 3.1 Layout Planning. Installer's preference determines choice of fasteners (use plastic zip ties for 3/4" tubing).

Note:
 Changing tubing sizes does not necessarily give you a higher heat output. The larger tubing allows for longer circuit lengths (refer to section 3.1 for maximum circuit lengths).

Tubing* (1/2" 5/8" 3/4")	Snow Melt Area (ft ²)	Multiplier	Estimated Amount
6" Spacing	500 ft ²	2.2	1100 ft
9" Spacing	500 ft ²	1.5	750 ft
12" Spacing	500 ft ²	1.1	550 ft

Fasteners*	Snow Melt Area (ft ²)	Multiplier	Estimated Amount
6" Spacing	500 ft ²	1.1	550
9" Spacing	500 ft ²	.75	375
12" Spacing	500 ft ²	.55	275

Table 2.5B

* Tubing is sold in coils and fasteners in packages.

2.6 Water/ Glycol Mixture:

Selecting the percentage of Glycol Mixture:

Freeze protection is essential to the snow melting system. For typical applications, Viega recommends using 40% Propylene Glycol. Ethylene Glycol is accepted. Use the table to determine the freezing point of the water/ glycol mixture based on % glycol by volume.

Glycol Mixture	Freezing Point (°F)	
	Ethylene Glycol	Propylene Glycol
30%	3.7	8.4
40%	-12.6	-6.7
50%	-35.0	-30.0

Table 2.6A

Note:

Automotive antifreeze is not recommended; the silicates in automotive antifreeze can coat and foul heat transfer surfaces and plug the system, reducing energy efficiency.

Glycol effects on the system:

The material properties change according to the % glycol mixture. Use the table to adjust the flow rate and pressure drop calculated through the tubing (refer to 2.7 and 3.8 for values).

Glycol Effects on the System		
Glycol Mixture	Flow Rate % Increase Multiplier	Pressure Drop % Increase Multiplier
30%	5% (1.05)	20% (1.20)
40%	8.5% (1.085)	25% (1.25)
50%	12.5% (1.125)	31% (1.31)

Table 2.6B

Procedure:

1. Use the table to find the % increase multiplier (based on the % glycol mixture).
2. Multiply the flow rate and pressure drop figures by the multiplier.

Example:

Glycol mixture: 40%

Calculated flow rate: 7 gpm
 Flow rate multiplier: 8.5% (1.085)
 Adjusted flow rate calculation:
 7 gpm x 1.085 = 7.6 gpm

Calculated pressure drop: 20 ft of hd
 Pressure drop multiplier: 25% (1.25)
 Adjusted pressure drop calculation:
 20 ft of hd x 1.25 = 25 ft of hd

Note: Perform this step last (after section 2.7 and 2.8) to simplify calculations.

Introducing the glycol solution into the snow melting system:

1. Figure the capacity of the entire system in gallons to determine the required amount of glycol (based on % solution) from:
 - Tubing (refer to data table)
 - Boiler (from manufacturer)
 - Additional tanks or reservoirs (from manufacturer)
2. Before injecting the glycol solution, thoroughly clean and flush the system.
3. The solution can be mixed outside the system in drums or barrels and then pumped in.

Pextron Tubing Data Table			
Nominal Size (in.)	Outside Diameter (in.)	Inside Diameter (in.)	Water Content (Gal/ft.)
1/2	0.625	0.475	0.009
5/8	0.750	0.574	0.014
3/4	0.875	0.671	0.018
1	1.125	0.862	0.030

Table 2.6C

Expansion Tank:

- Follow the procedures recommended by the expansion tank manufacturer to properly size a tank.
- Glycol solution expansion rate is approximately 1.2 times greater than that of water.
- Tank should be at least ~ 1.2 times larger than for a corresponding water filled system.

Notes:

- Mix solution at room temperature.
- Watch air vents during filling to prevent loss of solution.
- To avoid dilution, the system and the cold water supply should not be permanently connected (so automatic fill valves are usually not used).
- Use water that is soft and low in chloride and sulfate ions.

Fill and purge Kit:

Building a fill and purge kit will allow the fill and purge process to be quick, efficient, and easy. Figure 2.6A is an economical kit (parts supplied by others).

Kit consists of:

- 1) Barrel (~35 gal)
- 2) Double female 1" hoses
- 3) Puddle sucker
- 4) Pool pump
- 5) Pressure gauge
- 6) Bubble baffle

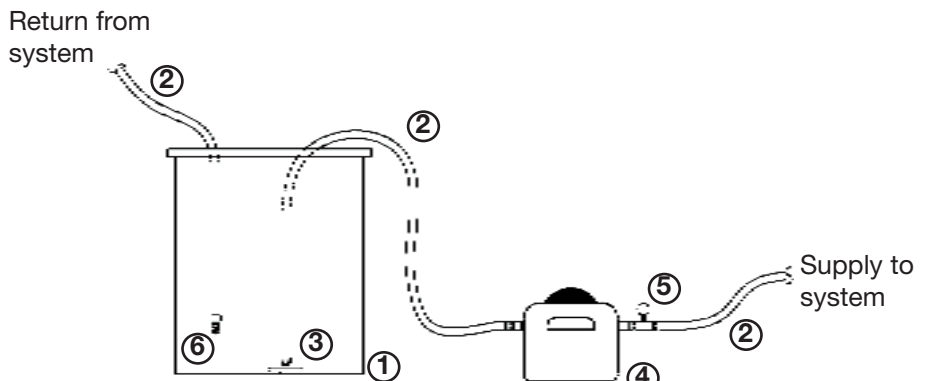

Figure 2.6A

Maintenance:

- Solutions should be checked each year using a suitable refractometer to determine glycol concentration.
- Check the concentration of corrosion inhibitor periodically, following procedures recommended by the glycol manufacturer.
- Typically glycol manufacturers offer a maintenance service for a reasonable cost.

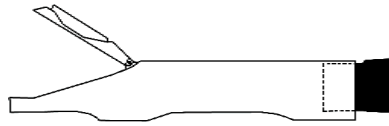

Figure 2.6B
Hand held refractometer:
 Used to read accurate fluid concentrations



Figure 2.6C
Ball-type tester:
 Used to estimate fluid concentrations

2.7 Calculating the Flow Rates:

Use this equation to calculate the flow rate of water with 0% Glycol.

$$\text{GPM} = \frac{\text{Total Btu (from section 3.2)}}{\Delta T \times 500}$$

For snow melting applications:
 $\Delta T = 30^\circ\text{F}$

$$\text{GPM} = \frac{\text{Total Btu (from section 3.2)}}{15000}$$

Then use the table “Glycol Effects on the System” on page 14 to calculate the flow rate needed based on % glycol mixture.

Note:
 This flow rate calculation is for the entire snow melting area; divide this number by the number of circuits (refer to section 3.5) in the area to calculate the flow rate through each circuit (with equal circuit lengths).

Example:
 Total BTU (refer to section 3.2) = 210 Btu/ h*ft² x 500 ft² = 105000 Btu/h
 Flow rate = 105000 Btu/ h ÷ 15000 = 7 gpm
 Flow rate per circuit = 7 gpm/ 3 equal circuits = 2.3 gpm/ circuit

2.8 Calculating the Pressure Drop:

Use the graph to determine the pressure drop through the longest circuit length with 0% glycol. Then use table "Glycol Effects on the System" on page 11 to calculate the pressure drop based on a % glycol mixture.

Procedure:

1. Locate desired flow rate for one circuit on the left vertical axis (refer to section 2.7 for calculating the flow rate).
2. Follow to the right until you reach the selected tubing size.
3. Then move down to the horizontal axis and read the pressure drop in feet of head per foot of tubing.
4. Multiply pressure drop per foot by length of longest circuit.
5. Use the table "Glycol Effects on the System" on page 18 to calculate the pressure drop based on a % glycol mixture.

Example:

GPM through 5/8" PEX: 2.2 gpm
 Pressure drop per foot: 0.062 ft of head / ft
 Total pressure drop: 0.062 x 250 total ft = 15.5 ft of head
 % Glycol mixture: 40%
 Pressure drop multiplier: 25% (1.25)
 Adjusted pressure drop calculation: 15.5 ft of head x 1.25 = 19.4 ft of head

PEX PRESSURE DROP CHART

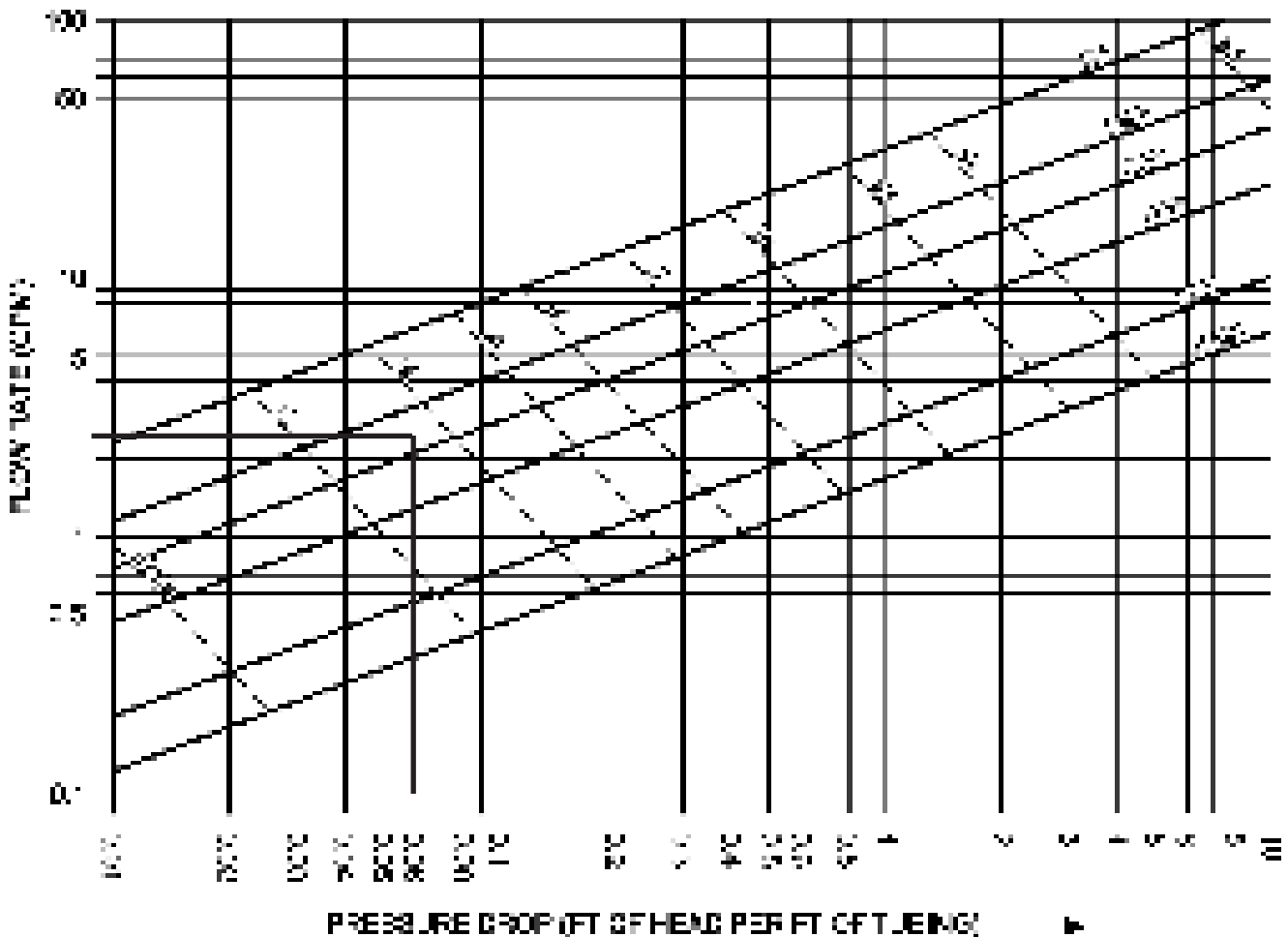

Figure 2.8

2.9 Selecting the Pump:

The pump must have a capacity equal to the system flow rate and a head equal to the system pressure loss. These two system characteristics are the primary ones in selecting a pump. Flow rates can be calculated in section 2.7 (Calculating the Flow Rate). Pressure drop can be calculated in section 2.8 (Calculating the Pressure Drop). Remember to use the highest pressure drop of all the circuits fed by their circulator. If the circulator can overcome that pressure drop, then it can overcome all the others.

Note:

Pump performance varies with temperature and viscosity of the water/glycol solution. Refer to pump curve chart from the pump manufacturer for detailed performance characteristics.

Procedure:

1. Locate the pressure drop on the left vertical axis.
2. Locate the total system flow rate on the bottom horizontal axis.
3. Follow to the intersection of both variables.
4. Select the pump with a curve higher than this point.

Example (see below):

Total GPM through 5/8" PEX:
8 gpm
Longest circuit pressure drop:
25 ft of head
Select the pump with a curve higher than this point.

Pump curve example

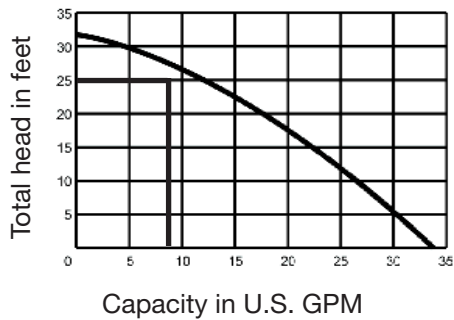

Figure 2.9

2.10 Approximating the Operating Cost:

Use this equation to calculate the cost to use a snow melting system for 1 year:

$$O = \frac{A \times q_a \times F}{[1 - (B/100)] \times (n_b \times n_e)}$$

where,

O = Operating cost (\$/yr)

A = Area (ft²)

q_a = Annual output (Btu/ft²),

refer to Appendix B

F = Fuel cost (\$/ Btu)

B = Back loss (%)

(refer to table 2.2B)

n_b = combustion efficiency of boiler, dimensionless

n_e = energy distribution efficiency, dimensionless

Note: This calculation is sensitive to the construction and control of the S-NO-ICE system. An advanced Snow Melt Control and accurate values used in the calculation is essential to approximate the operating cost.

Example:

A = 2000 ft²

q_a = 7694 Btu/ft² (in Boston)

F = assume \$0.000008 / Btu

B = 10%

n_b = 0.85

n_e = 0.90

Operating cost =

$$\frac{(2000 \times 7694 \times 0.000008)}{[1 - (10 \div 100)] \times 0.85 \times 0.90} = \$179 /yr$$

2.11 Selecting the Heat Exchanger:

For snow melt system, 100°F in - 130°F out (40% P.G.)
Connected to boiler, 180°F supply - 150°F return

Viega's heat exchangers are very cost effective in snow melt systems and provide high outputs, fast response and separation of the fluids.

Use the following procedure to select a heat exchanger for a snow melt system.

Procedure:

1. Determine the total Btuh required for the snow melt system.
2. Select the appropriate heat exchanger model from the table, based on the total Btuh required.
3. Check the total gpm required. If the gpm requirement of the snow melt system is greater than the gpm listed in the selection table, select a larger model to match the gpm and pressure drop needs, or install a bypass balancing valve. This will allow full flow and optimum pressure drop for the pump. This applies to the gpm on both boiler and glycol sides.

Viega Model	BTUH	Boiler Sides		Snow Melt Circuit	
		GPM	PSI gpm	GPM	PSI gpm
HX 4 (24" MPT)	20,000	1.3	0.3	1.4	0.1
HX 6 (24" MPT)	30,000	2.0	0.5	2.1	0.3
HX 8 (24" MPT)	40,000	2.7	1.0	2.8	0.4
HX 10 (24" MPT)	50,000	3.4	0.7	3.6	0.6
HX 12 (24" MPT)	60,000	4.1	1.0	4.3	0.7
HX 16 (24" MPT)	70,000	4.8	1.3	5.0	0.8
HX 18 (24" MPT)	80,000	5.5	1.6	5.7	1.0
HX 20 (24" MPT)	90,000	6.2	2.0	6.4	1.0
HX 24 (24" MPT)	100,000	6.9	2.3	7.2	1.1
* HX 28 (24" MPT)	120,000	8.6	2.8	8.9	1.1
HX 30 (1" MPT)	100,000	10.3	2.0	10.8	1.0
HX 34 (1" MPT)	170,000	12.0	2.4	12.6	1.0
HX 38 (1" MPT)	200,000	13.7	2.7	14.4	1.0
HX 42 (1" MPT)	220,000	15.5	2.9	16.2	1.1
* HX 46 (1" MPT)	250,000	17.2	3.2	18.0	1.1
* HX 50 (1" MPT)	270,000	18.9	3.6	19.8	1.2
HX 48 (1.5" MPT)	200,000	20.6	2.8	21.6	1.2
HX 52 (1.5" MPT)	280,000	24.3	3.4	25.2	1.3
HX 56 (1.5" MPT)	400,000	27.9	3.8	28.8	1.4
HX 60 (1.5" MPT)	480,000	31.6	4.2	32.4	1.4
* HX 70 (1.5" MPT)	500,000	34.9	4.8	35.1	1.6
HX 72 (1.5" MPT)	400,000	37.6	3.7	38.8	1.7
HX 82 (1.5" MPT)	500,000	34.3	3.8	32.4	1.6
HX 92 (1.5" MPT)	500,000	32.0	3.8	35.8	1.6
HX 102 (1.5" MPT)	600,000	41.3	3.7	42.3	1.6
HX 108 (2" MPT)	700,000	48.2	3.3	50.5	1.6
HX 108 (2" MPT)	800,000	55.1	3.0	57.7	1.6
HX 108 (2" MPT)	900,000	62.0	3.0	64.9	1.6
HX 120 (2" MPT)	1,000,000	68.9	2.9	72.1	1.6

Table 2.11

* Stocked models (other models have a 3-4 week lead time)

Notes:

For 200°F boiler water, use the above chart. For 160°F boiler water, multiply model number by 1.66 and round up to next available size.

For steam use use the above chart, substituting Marine models.

3.1 Thermal Mass:

Concrete, pavers, or asphalt may be used in snow melting systems.

Concrete:

Refer to cement manufacturer for recommended compressive strength, slump, aggregate size, and air content.

Typical applications:

- Compressive strength ~ 4000 to 5000 psi
- Slump ~ 3 in. maximum, 2 in. minimum
- Typical 2" concrete above tubing

Asphalt:

- Hot asphalt can damage tubing (refer to cross sections for installation)
- Lower thermal conductivity than concrete
- Finest grade asphalt is best
- Stone diameter should not exceed 0.38 in.
- Typical 1-1/2" sand bed above tubing
- Tubing should be secured to the insulation to prevent contact with the hot asphalt

Pavers:

- Space tubing 2 inches closer for each additional inch of pavers > 2-3/8" pavers
- Typical 1-1/2" sand bed above tubing

3.2 Typical Cross Sections:

Section through slab on grade installation using Foam Staples

- Install foam board insulation (1" minimum, R-5).
- Use Foam Staple Gun to drive Foam Staples to hold tubing to foam board.
- Foam Staples are 2-1/2" in length to easily penetrate 1" foam board for good holding power.

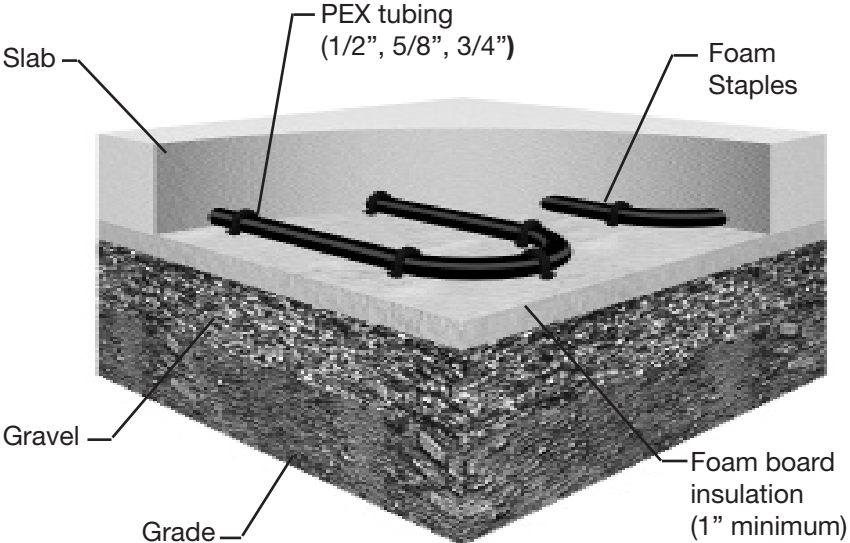

Figure 3.2A

Note: A moisture barrier (polyethylene film) on top of the gravel is recommended.

Section through slab on grade installation using Plastic Clips

- Install foam board insulation (1" minimum, R-5).
- Screw Plastic Clips into foam board insulation.
- Snap PEX tubing into Plastic Clips.

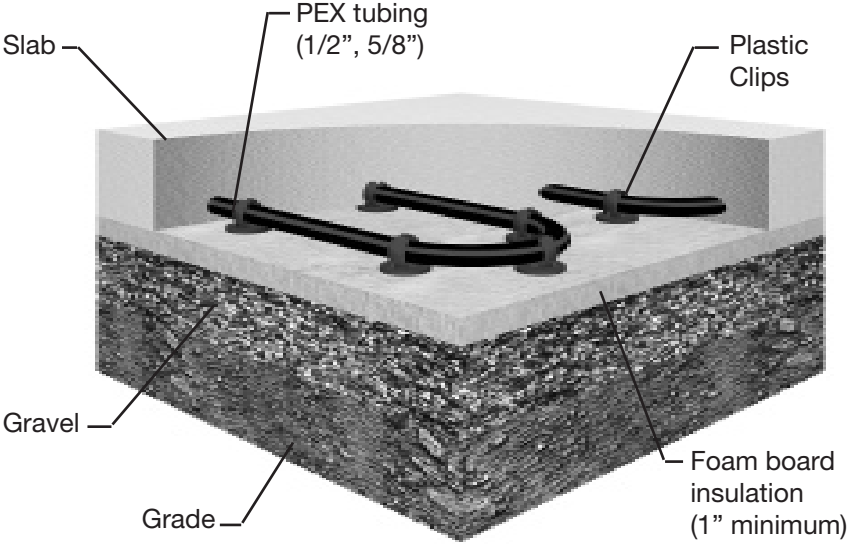

Figure 3.2B

Note: A moisture barrier (polyethylene film) on top of the gravel is recommended.

Section through slab on grade installation using Wire Mesh Clips

- Install foamboard insulation (1" minimum, R-5).
- Install wire mesh.
- Fasten PEX tubing to wire mesh using Wire Mesh Clips.
- Chairs/ bricks may be used to raise the wire mesh and tubing to the mid point of the slab.

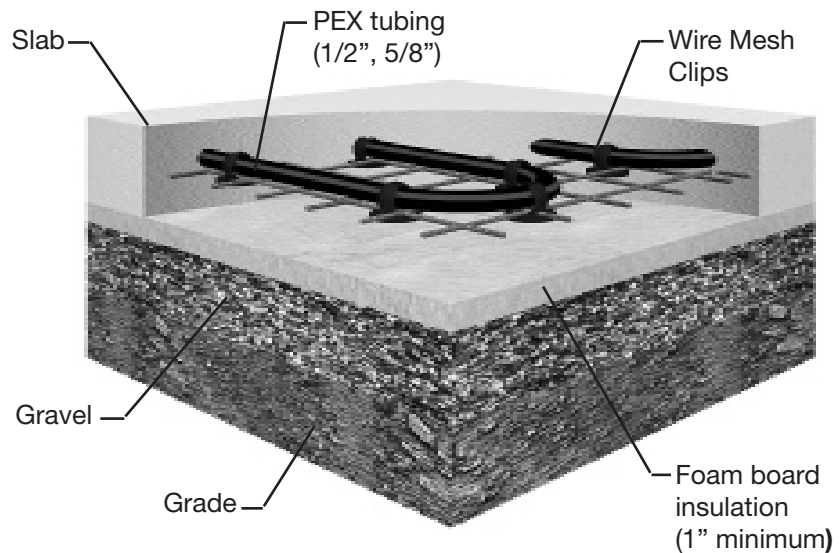

Figure 3.2C

Note:
A moisture barrier (polyethylene film) on top of the gravel is recommended.

Section through slab on grade installation using Plastic Zip Ties

- Install foamboard insulation (1" minimum, R-5).
- Install wire mesh.
- Fasten PEX tubing to wire mesh using plastic zip ties.
- Chairs/ bricks may be used to raise the wire mesh and tubing to the mid point of the slab.

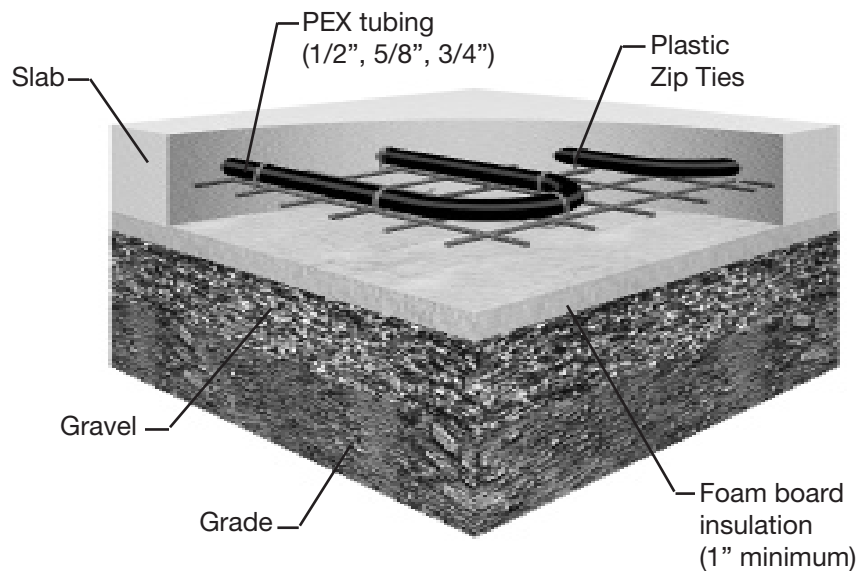

Figure 3.2D

Note:
A moisture barrier (polyethylene film) on top of the gravel is recommended.

SNOW MELT SYSTEM INSTALLATION - CHAPTER 3

Section through slab on grade installation using U-Channels

- Install foamboard insulation (1" minimum, R-5).
- Snap PEX tubing into U-Channel (tubing insertion points are every 2 inches).

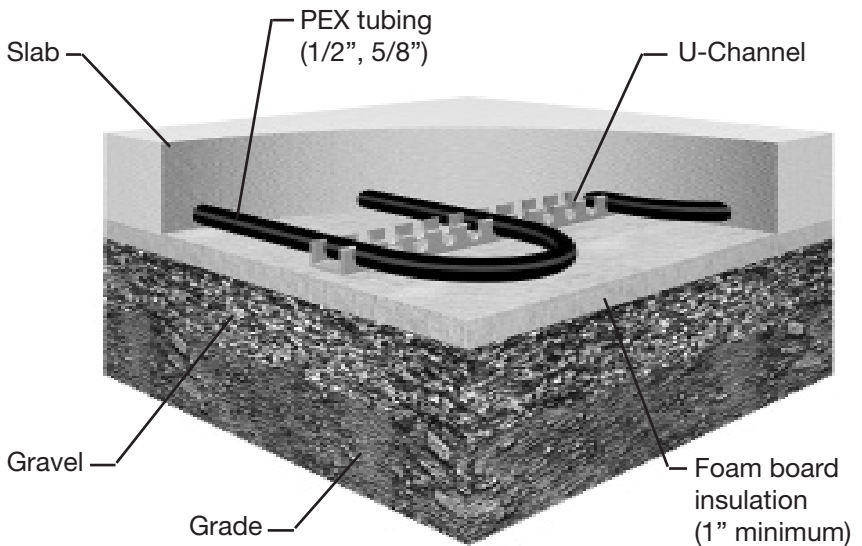

Note:
A moisture barrier (polyethylene film) on top of the gravel is recommended.

Figure 3.2F

Section through pavers over sand bed with insulation

- Install foam board insulation (1" minimum, R-5).
- Screw Plastic Clips into foam board insulation.
- Snap PEX tubing into Plastic Clips.

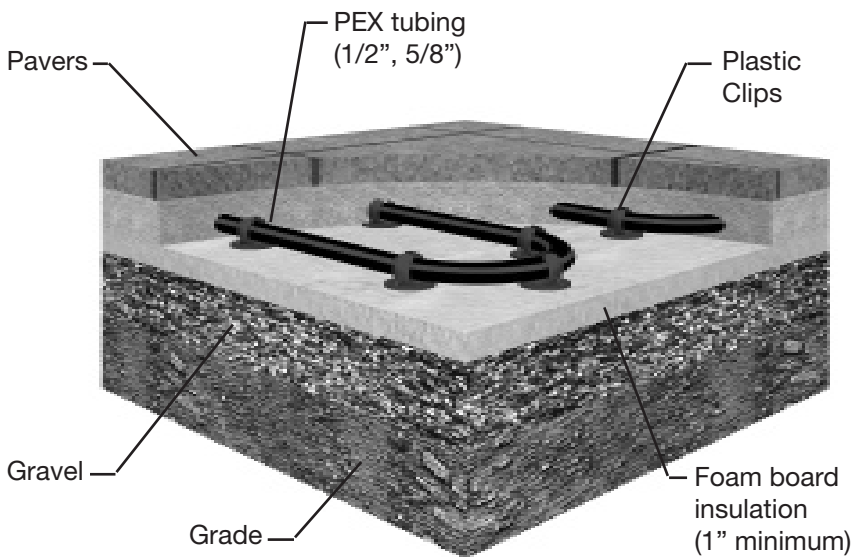
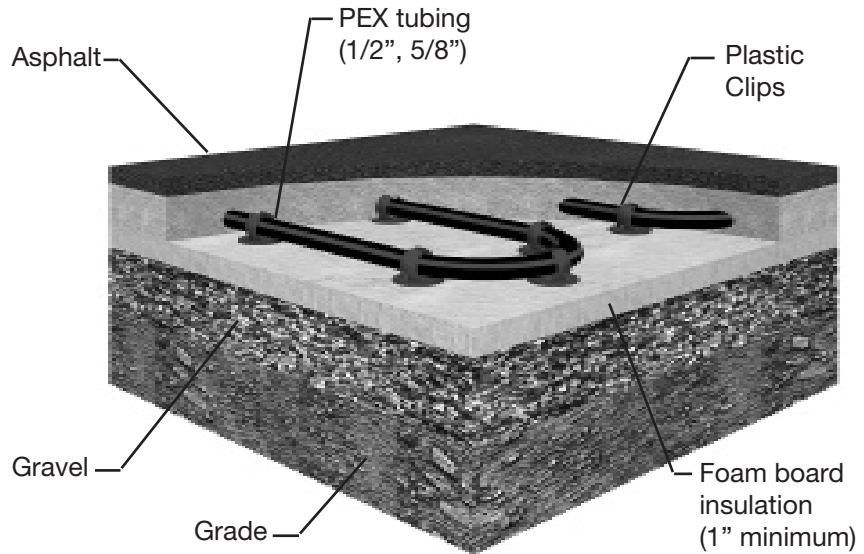

Figure 3.2F

Extruded polystyrene (XPS) is recommended.

Section through asphalt over sand or stone dust bed with insulation

- Install foam board insulation (1" minimum, R-5).
- Screw Plastic Clips into foam board insulation.
- Snap PEX tubing into Plastic Clips.



Note:
A moisture barrier (polyethylene film) on top of the gravel is recommended.

Figure 3.2G

Section through thin-slab over structural slab

- Install foamboard insulation (1" minimum, R-5).
- Install wire mesh.
- Fasten PEX tubing to wire mesh using plastic zip ties.
- Structural slab (lower) must be designed to provide the total strength.

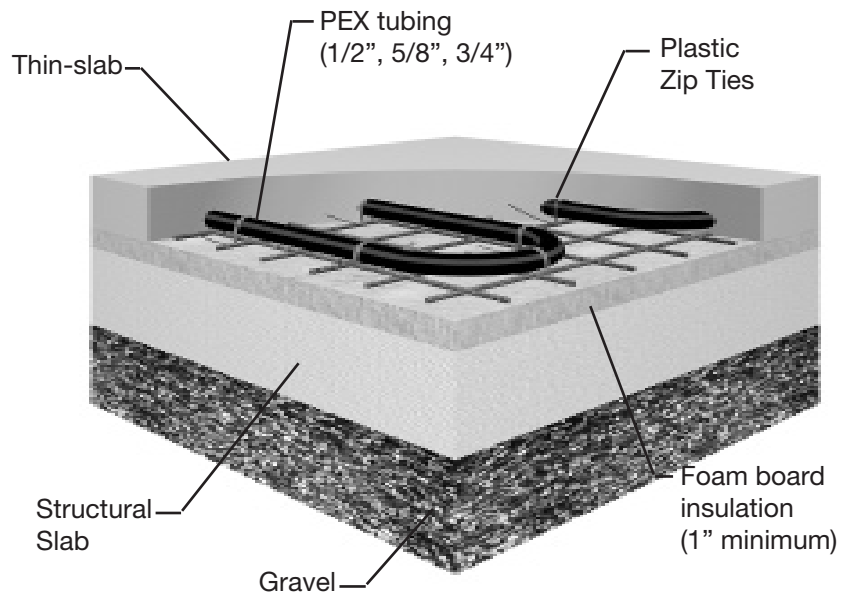

Note:
A moisture barrier (polyethylene film) on top of the gravel is recommended.

Figure 3.2H

SNOW MELTING SYSTEM INSTALLATION - CHAPTER 3

3.3 Selecting the Control Package:

Basic snow melting control package

Under these applications the basic snow melting control package is recommended:

- Economical system required
- Snow sensor cannot be mounted in thermal mass

Note:
Refer to page 10 and to product instructions supplied with the Basic Snow Melt Control for more detailed information.

This package is not ordered as one entity. Use table 3.4A for reference when ordering necessary parts for the selected package.

Basic Snow Melt Control Components

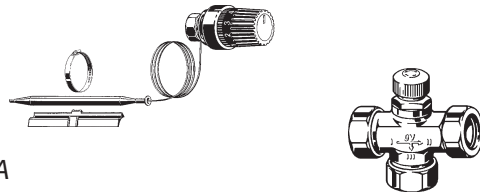
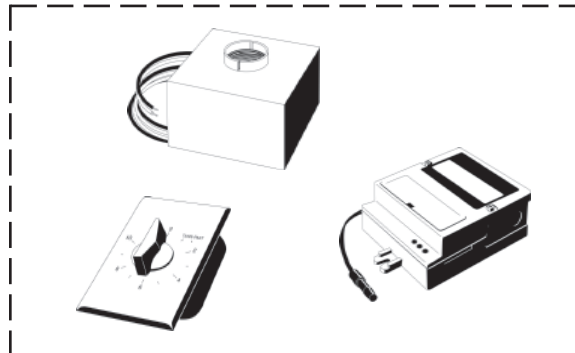

Figure 3.3A

Advanced snow melting control package

Under these applications the advanced snow melting control package is recommended:

- Slab protection (the control limits the rate at which heat can be applied to the slab through the ΔT Max setting)
- High sensor sensitivity required
- Boiler and DHW control capabilities required
- Alarm capability required
- Idling necessary

Note:
Refer to page 10 and to product instructions supplied with the Advanced Snow Melt Control for more detailed information.
This package is not ordered as one entity. Use table 3.4B for reference when ordering necessary parts for the selected package.

Advanced Snow Melt Control Components

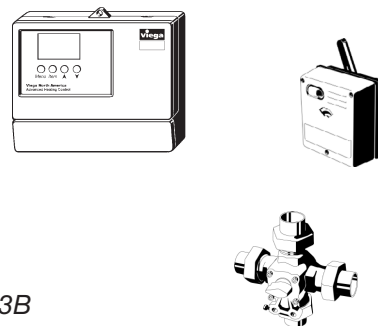
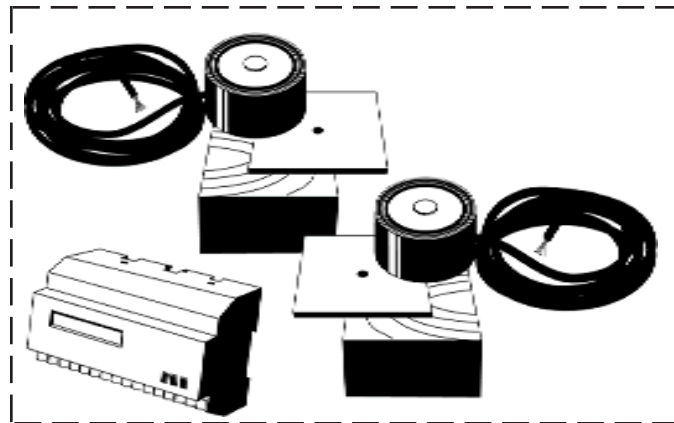

Figure 3.3B

3.4 Schematics - Piping and Controls:

Basic snow melting control package

Material	Quantity	Stock Code
Diverting Valve	1	20 001-003,041
Non-Electric Fixed Water Temp. Control	1	16 102-105
Basic Snow Melt Control	1	17 012
Heat Exchanger	1	22 006-008
1" Manifold, # outlets^	#^	15 012-022
Manifold Accessory Set	#^	15 023
Transformer 24V	1	18 008, 020

Table 3.4A

* Based on job requirements

Note: Use 1-1/2" manifold when flow rates are >13 GPM.

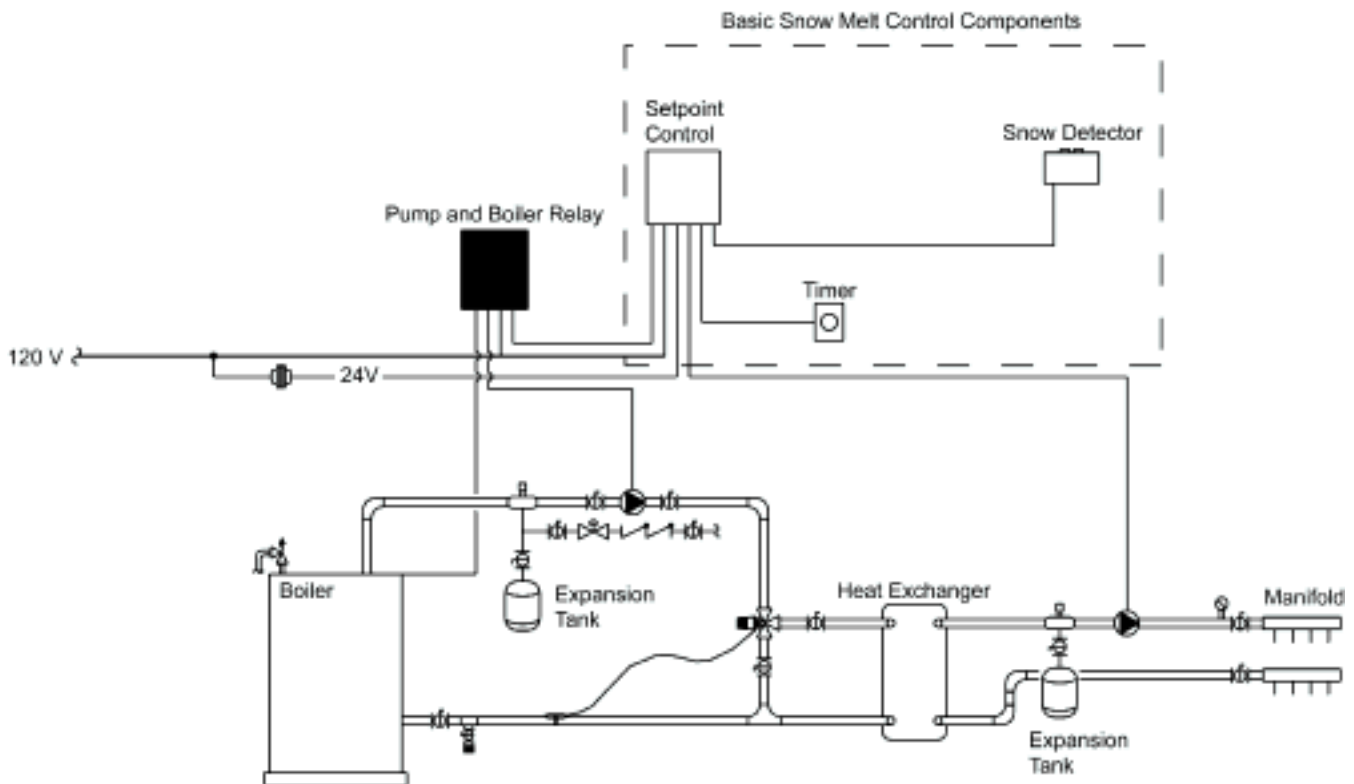

Figure 3.4A

Note:

All schematics are conceptual. The designer must determine whether this application will work in the system and must ensure compliance with National and Local code requirements. Boiler trim (expansion tank, fill valve, etc.) supplied by others.

SNOW MELTING SYSTEM INSTALLATION - CHAPTER 3

Advanced snow melting control package

Material	Quantity	Stock Code
Mixing Valve	1	20 017-020, 025-028
Three Position Actuator	1	18 018, 019
Advanced Heating Control	1	16 014
Boiler Return Sensor (universal sensor)	1	16 018
Optional DHW Sensor (universal sensor)	1	16 018
Advanced Snow Melt Control	1	17 005
Heat Exchanger	1	22 006-008
1" Manifold, # outlets^	#^	15 012-022
Manifold Accessory Set	#^	15 023
Transformer 24V	1	18 008, 020

Application:
 Medium to large residential,
 commercial and industrial areas,
 Level II & III (refer to page 13 for
 Level description)

Table 3.4B

* Based on job requirements

Note: Use 1-1/2" manifold when flow rates are >13 GPM.

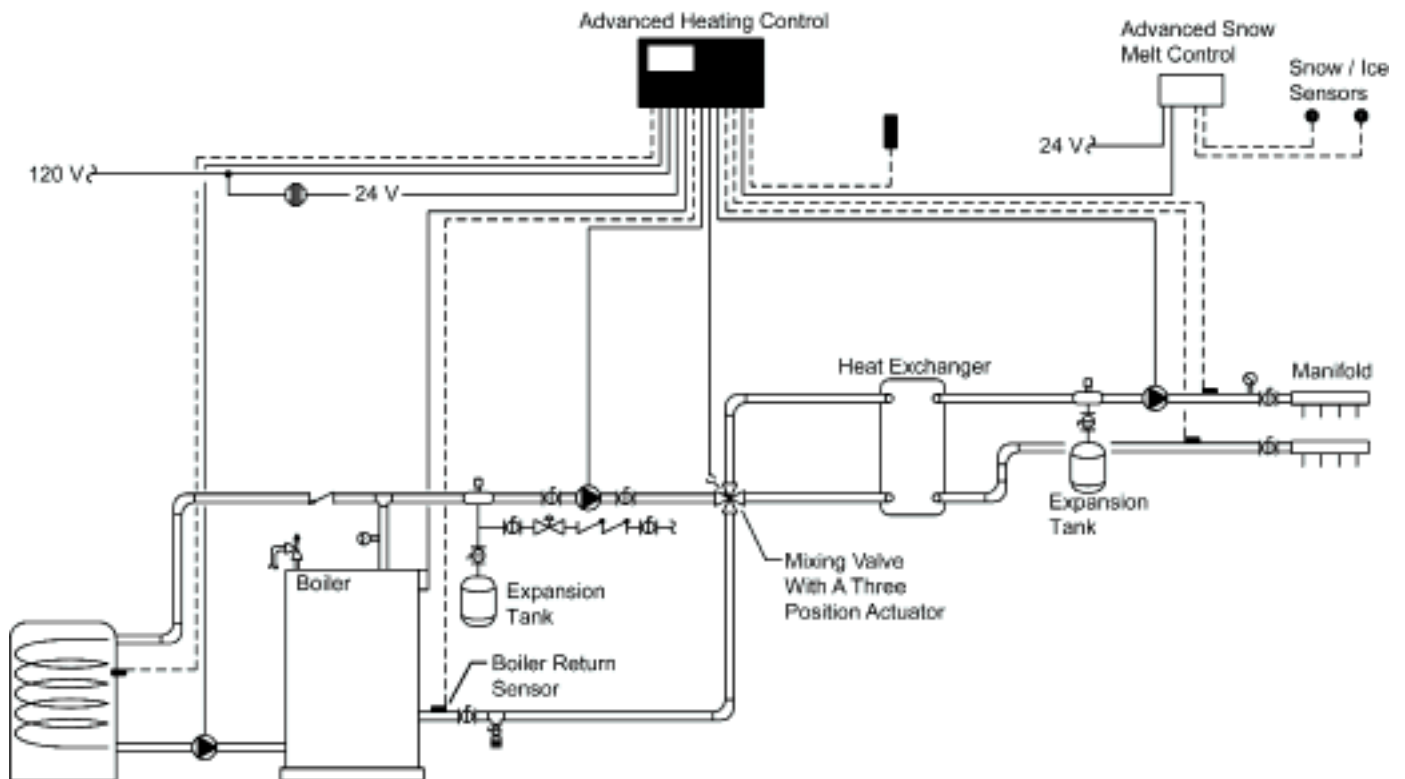

Figure 3.4B

3.5 Layout Planning:

To avoid waste and to have equal circuit lengths, a carefully planned layout should be done.

First, determine where the manifold should be installed. Remember the manifold must be accessible.

When calculating the number of circuits, always round up! Keep the length of each circuit the same in the snow melt area.

Tube Size	Max. Circuit Length
1/2"	150 ft
5/8"	250 ft
3/4"	400 ft

Table 3.5

Calculating number of circuits:

$$\text{Total amount of tubing} \div \text{Maximum circuit length} = \# \text{ of circuits}$$

Circuit layout patterns for snow melting

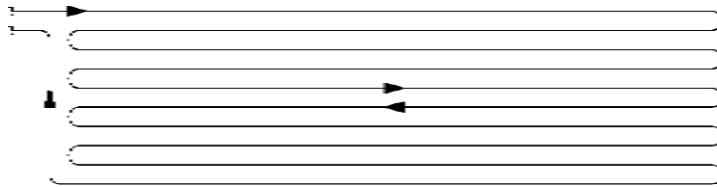

Figure 3.5A

Serpentine

Used in Level I and II applications (refer to page 13 for Level descriptions)

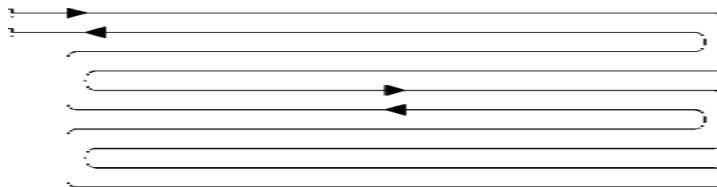

Figure 3.5B

Reverse return

Level I and II optional, recommended for Level III applications (refer to page 13 for Level descriptions).

This pattern distributes heat more evenly and allows a lower thermal stress than a serpentine pattern. The reverse return installation procedure is more difficult and more time consuming than that of the serpentine pattern.

Ensure proper drainage for snow melting area. Refer to Appendix C.

SNOW MELTING SYSTEM INSTALLATION - CHAPTER 3

Tubing layout around joints

Concrete has very little flexibility and will almost always crack. Jointing is one of the best ways to control the inevitable. Joint location, which influences the radiant heating piping design layout, is generally specified by the architect.

Typical joint locations:

- Side length $\leq 18'$
- Sides less than 1:2 ratio

Control Joints:

Control joints force cracks to follow the path of the joint. Without them, random cracks will ruin the appearance and sometimes the usefulness of the slab. Tubing shall be sleeved at all joints (control and expansion). Refer to Appendix D.

Slabs with Control Joints

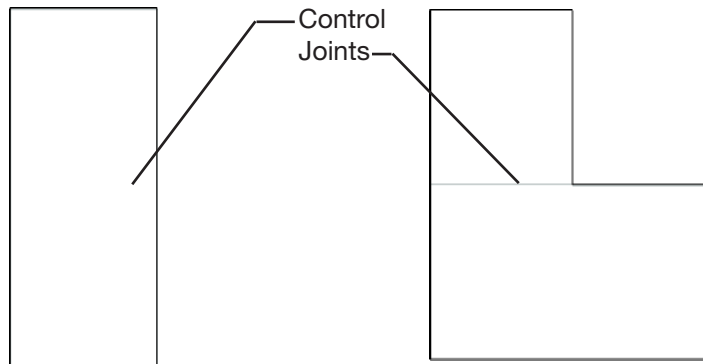

Figure 3.5C

Minimize Penetration of Joints
(Refer to Appendix D for Typical Cross Sections)

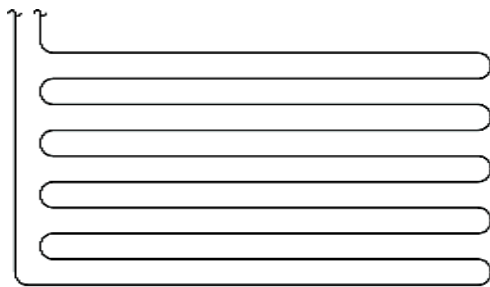
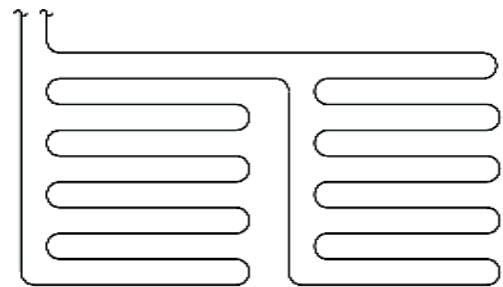

Figure 3.5D

Incorrect



Correct

3.6 Snow Melting System Installation:

Step 1:

Installing the insulation

- Final grade should be accurately leveled.
- Cover grade with a polyethylene film (6 mil minimum).
(Not recommended in paver applications.)

Insulation:

- Must have the proper compressive strength rating for each application.
- Must be capable of withstanding the moisture conditions.

Note:

Weigh down the foam boards to prevent wind uplift. In some jobs this can be done by installing wire mesh as soon as foam boards are placed. The insulation must have the proper compressive strength rating for each application.

Insulation Benefits:

- Increased response time
- Increased energy savings
- Decreased downward heat loss

Outside of the slab, insulate all PEX supply and return lines with pipe insulation.

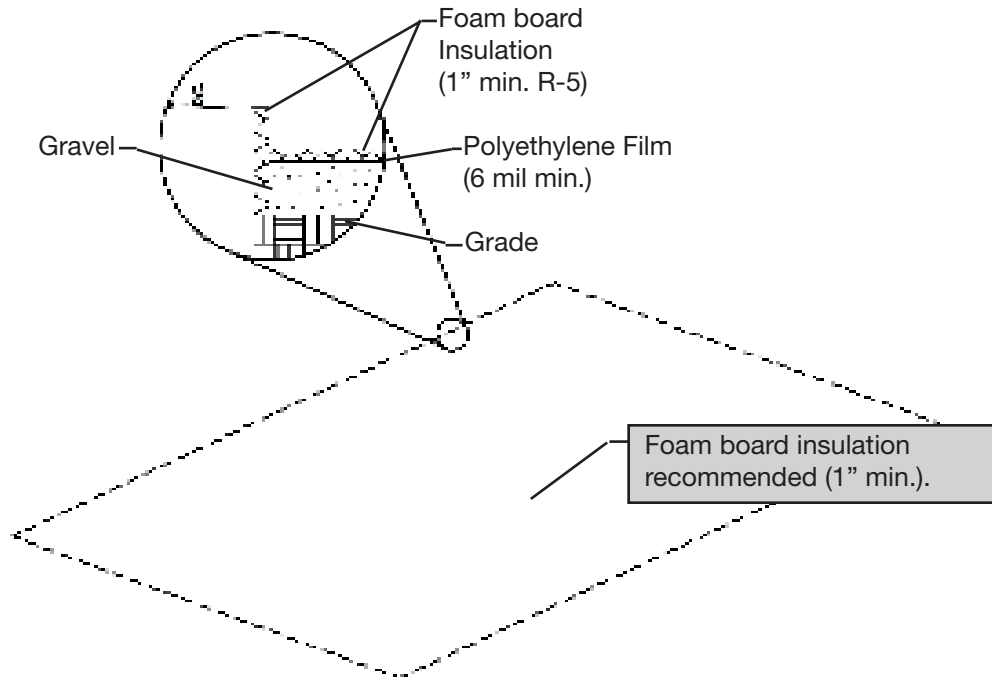

Figure 3.6A

Check with local codes for requirements related to insulation.

Step 2:

Installing the tubing

Fasten tubing every two feet and 3 times at each u-turn to hold down any return bends or other shapes created. It's helpful to mark out portions of each circuit directly on the insulation using spray paint.

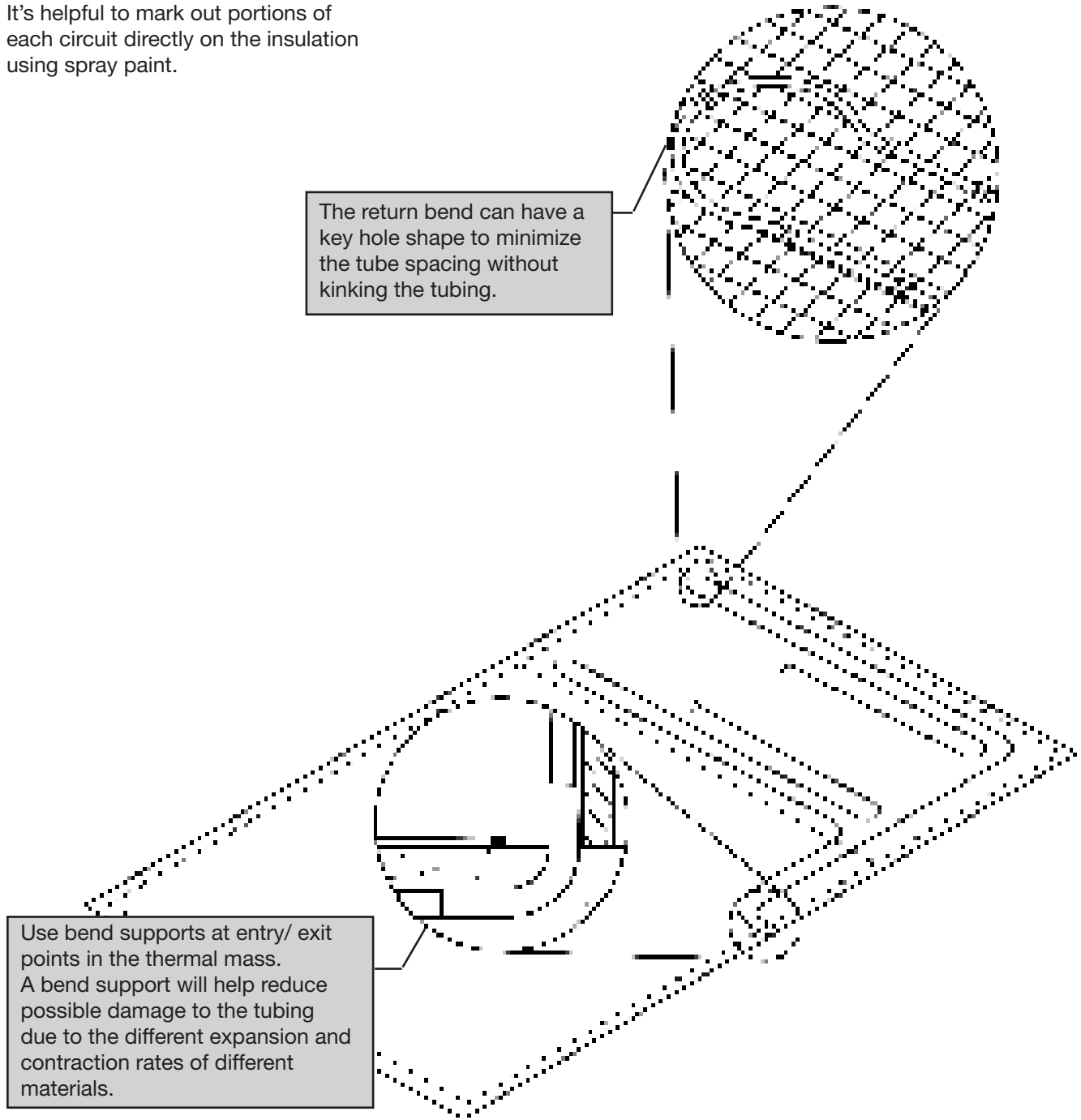

Figure 3.6B

Step 3:

Pressurizing the tubing

- Pressurize tubing to 80 psi 24 hours before pour and leave pressurized until slab is cured.
- Re-tighten any tubing couplings located in the slab area after at least 12 hours of system pressurization.

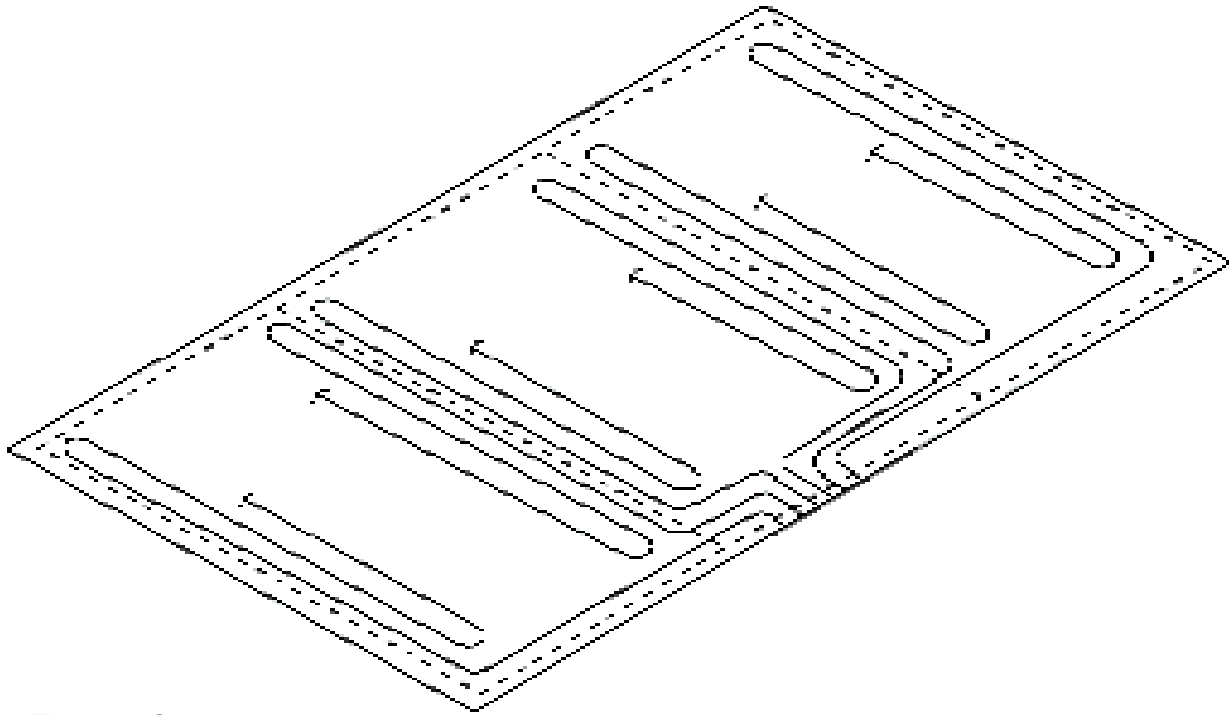

Figure 3.6C

All tubing must be pressure tested prior to and during pour!
(Refer to section 4.1 Pressure Testing)

SYSTEM STARTUP - CHAPTER 4

4.1 Pressure Testing:

Air or water may be used as the medium in pressure testing a snow melting system. The following four step procedure is recommended by Viega. Check the local building codes for compliance or additional test requirements.

Note:

If the tubing was damaged, repair punctured section with a compression coupling.

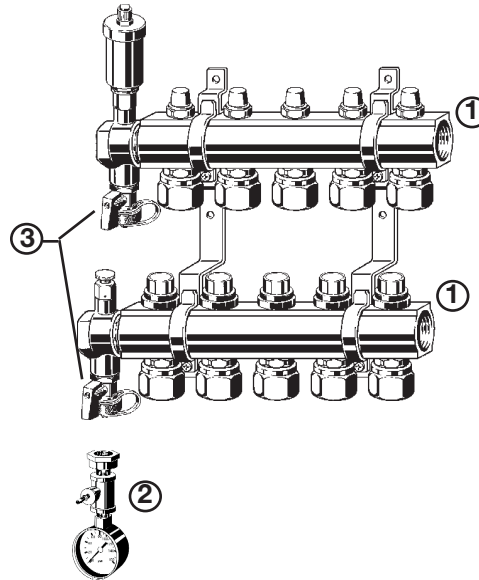

Figure 4.1

Procedure:

1. Double check all connections to manifold to ensure proper seal (cap ends (1) if needed).
2. Connect System Pressurization Kit (2) to any purge valve (3).
3. Pressurize the system to 80 psi to detect potential penetrations.
4. The system should hold the 80 psi for a minimum of 24 hours.

4.2 Filling and Purging the System:

After completing the pressure test successfully, use the following procedure to fill and purge the system.

Procedure:

1. Close ball valves (1) to isolate the manifold.
2. Connect the fill and purge kit (refer to page 19) to the purge valves on the manifold (2).
3. Fill and purge the manifold and tubing (one circuit at a time).
4. Open the ball valves (1) to fill and purge the rest of the snow melt system piping.

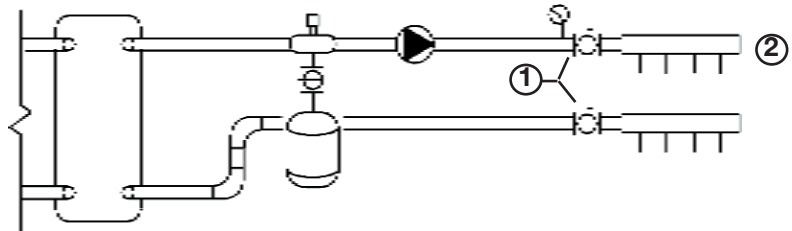

Figure 4.2

PRESSURE DROP CHARTS - APPENDIX A

Pressure Drop (ft of head per ft)				
110°F, 30% Propylene Glycol				
Tubing Size				
Flow Rate (gpm)	1/2"	5/8"	3/4"	1"
0.2	0.0035	0.0017	0.0009	0.0003
0.4	0.0072	0.0034	0.0018	0.0007
0.5	0.0109	0.0051	0.0027	0.0010
0.8	0.0145	0.0068	0.0035	0.0013
1	0.0495	0.0085	0.0045	0.0017
1.2	0.0682	0.0278	0.0055	0.0020
1.4	0.0893	0.0354	0.0173	0.0023
1.5	0.1123	0.0460	0.0219	0.0057
1.8	0.1385	0.0555	0.0259	0.0052
2	0.1657	0.0690	0.0323	0.0098
2.2	0.1969	0.0804	0.0382	0.0115
2.4	0.2293	0.0905	0.0445	0.0135
2.5	0.2538	0.1077	0.0512	0.0155
2.8	0.3003	0.1225	0.0583	0.0177
3	0.3388	0.1383	0.0558	0.0200
3.2	0.3793	0.1548	0.0735	0.0224
3.4	0.4218	0.1722	0.0819	0.0249
3.5	0.4552	0.1903	0.0905	0.0275
3.8	0.5124	0.2092	0.0994	0.0303
4	0.5605	0.2288	0.1088	0.0331
4.2	0.6105	0.2492	0.1185	0.0351
4.4	0.6623	0.2704	0.1285	0.0391
4.5	0.7159	0.2922	0.1389	0.0423
4.8	0.7712	0.3148	0.1497	0.0455
5	0.8283	0.3381	0.1608	0.0490

PRESSURE DROP CHARTS - APPENDIX A

		Pressure Drop (ft of head per ft) 140°F, 30% Propylene Glycol			
		Tubing Size			
Flow Rate (gpm)	1/2"	5/8"	3/4"	1"	
0.2	0.0025	0.0012	0.0006	0.0002	
0.4	0.0050	0.0023	0.0012	0.0005	
0.6	0.0074	0.0035	0.0019	0.0007	
0.8	0.0098	0.0047	0.0025	0.0009	
1	0.0121	0.0059	0.0031	0.0011	
1.2	0.0144	0.0071	0.0037	0.0013	
1.4	0.0167	0.0083	0.0043	0.0015	
1.6	0.0190	0.0095	0.0049	0.0017	
1.8	0.0213	0.0107	0.0055	0.0019	
2	0.0236	0.0119	0.0061	0.0021	
2.2	0.0259	0.0131	0.0067	0.0023	
2.4	0.0282	0.0143	0.0073	0.0025	
2.6	0.0305	0.0155	0.0079	0.0027	
2.8	0.0328	0.0167	0.0085	0.0029	
3	0.0351	0.0179	0.0091	0.0031	
3.2	0.0374	0.0191	0.0097	0.0033	
3.4	0.0397	0.0203	0.0103	0.0035	
3.6	0.0420	0.0215	0.0109	0.0037	
3.8	0.0443	0.0227	0.0115	0.0039	
4	0.0466	0.0239	0.0121	0.0041	
4.2	0.0489	0.0251	0.0127	0.0043	
4.4	0.0512	0.0263	0.0133	0.0045	
4.6	0.0535	0.0275	0.0139	0.0047	
4.8	0.0558	0.0287	0.0145	0.0049	
5	0.0581	0.0299	0.0151	0.0051	

PRESSURE DROP CHARTS - APPENDIX A

Pressure Drop (ft of head per ft) 110°F, 40% Propylene Glycol				
Tubing Size				
Flow Rate (gpm)	1/2"	5/8"	3/4"	1"
0.2	0.0048	0.0023	0.0012	0.0004
0.4	0.0097	0.0046	0.0024	0.0009
0.6	0.0145	0.0069	0.0036	0.0013
0.8	0.0193	0.0091	0.0049	0.0018
1	0.0241	0.0113	0.0061	0.0022
1.2	0.0289	0.0136	0.0073	0.0027
1.4	0.0337	0.0159	0.0085	0.0031
1.6	0.0385	0.0182	0.0097	0.0036
1.8	0.0433	0.0205	0.0109	0.0040
2	0.0481	0.0228	0.0121	0.0045
2.2	0.0529	0.0251	0.0133	0.0050
2.4	0.0577	0.0274	0.0145	0.0055
2.6	0.0625	0.0297	0.0157	0.0060
2.8	0.0673	0.0320	0.0169	0.0065
3	0.0721	0.0343	0.0181	0.0070
3.2	0.0769	0.0366	0.0193	0.0075
3.4	0.0817	0.0389	0.0205	0.0080
3.6	0.0865	0.0412	0.0217	0.0085
3.8	0.0913	0.0435	0.0229	0.0090
4	0.0961	0.0458	0.0241	0.0095
4.2	0.1009	0.0481	0.0253	0.0100
4.4	0.1057	0.0504	0.0265	0.0105
4.6	0.1105	0.0527	0.0277	0.0110
4.8	0.1153	0.0550	0.0289	0.0115
5	0.1201	0.0573	0.0301	0.0120

PRESSURE DROP CHARTS - APPENDIX A

Flow Rate (gpm)	Pressure Drop (fto head per ft) 140°F, 40% Propylene Glycol			
	Tubing Size			
	1/2"	5/8"	3/4"	1"
0.2	0.0032	0.0015	0.0008	0.0003
0.4	0.0063	0.0030	0.0015	0.0005
0.6	0.0095	0.0045	0.0024	0.0009
0.8	0.0124	0.0060	0.0032	0.0012
1	0.0179	0.0135	0.0040	0.0015
1.2	0.0260	0.0209	0.0128	0.0018
1.4	0.0364	0.0303	0.0168	0.0051
1.6	0.1091	0.0445	0.0212	0.0064
1.8	0.1341	0.0547	0.0260	0.0079
2	0.1612	0.0658	0.0313	0.0095
2.2	0.1905	0.0778	0.0370	0.0113
2.4	0.2218	0.0905	0.0431	0.0131
2.6	0.2552	0.1042	0.0495	0.0151
2.8	0.2905	0.1186	0.0564	0.0172
3	0.3278	0.1338	0.0636	0.0194
3.2	0.3670	0.1498	0.0712	0.0217
3.4	0.4081	0.1666	0.0792	0.0241
3.6	0.4510	0.1841	0.0875	0.0267
3.8	0.4958	0.2024	0.0962	0.0293
4	0.5423	0.2214	0.1053	0.0321
4.2	0.5907	0.2411	0.1146	0.0349
4.4	0.6408	0.2615	0.1244	0.0379
4.6	0.6925	0.2827	0.1344	0.0409
4.8	0.7462	0.3046	0.1448	0.0441
5	0.8014	0.3271	0.1555	0.0474

PRESSURE DROP CHARTS - APPENDIX A

Pressure Drop (fto head per ft) 110°F, 50% Propylene Glycol				
Tubing Size				
Flow Rate (gpm)	1/2"	5/8"	3/4"	1"
0.2	0.0057	0.0031	0.0017	0.0006
0.4	0.0134	0.0063	0.0034	0.0012
0.6	0.0201	0.0094	0.0051	0.0019
0.8	0.0268	0.0126	0.0067	0.0025
1	0.0335	0.0157	0.0084	0.0031
1.2	0.0402	0.0189	0.0101	0.0037
1.4	0.0469	0.0220	0.0118	0.0043
1.6	0.0536	0.0252	0.0135	0.0049
1.8	0.1616	0.0283	0.0152	0.0055
2	0.1944	0.0793	0.0168	0.0062
2.2	0.2296	0.0837	0.0185	0.0069
2.4	0.2674	0.1092	0.0519	0.0074
2.6	0.3076	0.1296	0.0537	0.0080
2.8	0.3502	0.1430	0.0680	0.0087
3	0.3952	0.1513	0.0767	0.0094
3.2	0.4424	0.1606	0.0859	0.0099
3.4	0.4919	0.2008	0.0935	0.0099
3.6	0.5437	0.2219	0.1055	0.0321
3.8	0.5976	0.2440	0.1160	0.0353
4	0.6538	0.2669	0.1269	0.0385
4.2	0.7120	0.2907	0.1382	0.0421
4.4	0.7724	0.3153	0.1499	0.0455
4.6	0.8349	0.3408	0.1620	0.0493
4.8	0.8995	0.3672	0.1745	0.0532
5	0.9661	0.3944	0.1875	0.0571

PRESSURE DROP CHARTS - APPENDIX A

		Pressure Drop (fto head per ft) 140°F, 50% Propylene Glycol			
		Tubing Size			
Flow Rate (gpm)	1/2"	5/8"	3/4"	1"	
0.2	0.0042	0.0020	0.0011	0.0004	
0.4	0.0085	0.0040	0.0021	0.0008	
0.6	0.0127	0.0060	0.0032	0.0012	
0.8	0.0170	0.0080	0.0043	0.0016	
1	0.0212	0.0100	0.0053	0.0020	
1.2	0.0254	0.0120	0.0064	0.0024	
1.4	0.0297	0.0139	0.0075	0.0027	
1.6	0.1174	0.0479	0.0228	0.0081	
1.8	0.1443	0.0589	0.0280	0.0085	
2	0.1735	0.0708	0.0337	0.0103	
2.2	0.2050	0.0837	0.0398	0.0121	
2.4	0.2387	0.0974	0.0463	0.0141	
2.6	0.2745	0.1121	0.0533	0.0162	
2.8	0.3125	0.1276	0.0607	0.0185	
3	0.3527	0.1440	0.0684	0.0208	
3.2	0.3949	0.1612	0.0766	0.0233	
3.4	0.4390	0.1792	0.0852	0.0259	
3.6	0.4852	0.1981	0.0942	0.0287	
3.8	0.5334	0.2177	0.1035	0.0315	
4	0.5835	0.2382	0.1132	0.0345	
4.2	0.6355	0.2594	0.1233	0.0376	
4.4	0.6894	0.2814	0.1338	0.0407	
4.6	0.7451	0.3042	0.1445	0.0440	
4.8	0.8028	0.3277	0.1558	0.0474	
5	0.8622	0.3520	0.1673	0.0510	

ANNUAL OPERATING DATA - APPENDIX B

Annual Heat Flux Requirements: Btu/ft ² /hr			
City	Level I	Level II	Level III
Albany, NY	4871	7252	10132
Albuquerque, NM	934	1729	2455
Amarillo, TX	1357	3314	5278
Billings, MT	3718	10328	17270
Bismarck, ND	2300	3821	16295
Boise, ID	1845	2449	3543
Boston, MA	3213	5455	7894
Buffalo, NY	5533	14935	23229
Burlington, VT	3733	3435	13132
Cheyenne, WY	3732	11321	20061
Chicago, IL (Chicago Int'l AP)	2252	5402	3501
Cleveland, OH	3203	7359	11489
Colorado Springs, CO	3033	7039	11137
Columbus, OH (Int'l AP)	1337	2972	4331
Des Moines, IA	2354	3793	10334
Detroit, MI (Metro)	2704	3437	10199
Duluth, MN	3939	12423	20333
Elk, WY	3033	5233	7421
Eugene, OR	429	334	334
Fairbanks, AK	3559	11700	19303
Baltimore, MD (BWI AP)	2121	2970	3327
Great Falls, MT	3733	11731	19703
Indianapolis, IN	1705	4332	3553
Lexington, KY	733	1713	2393
Madison, WI	3024	7279	11404
Memphis, TN	373	391	1010
Minneapolis, MN	3331	7334	11373
Minneapolis-St. Paul, MN	4097	10325	13332
New York, NY (JFK AP)	1797	2933	4133
Oklahoma City, OK	733	1359	2955
Omaha, NE	1790	4313	7425
Peoria, IL	1303	4073	3544
Philadelphia, PA (Int'l AP)	1533	3339	3753
Pittsburgh, PA (Int'l AP)	2333	3359	10329
Portland, ME	4339	3939	13313
Portland, OR	370	434	333
Portland City, SD	2533	9733	13339
Reno, NV	1302	1732	2293
Salt Lake City, UT	3233	4271	5233
Sault Ste. Marie, MI	7259	20779	34349
Seattle, WA	332	343	1212
Spokane, WA	2512	4721	3909
Springfield, MO	1503	2959	4391
St. Louis, MO (Int'l AP)	1433	2931	4513
Topoka, KS	1133	2321	4307
Wichita, KS	1229	3103	4331

* Annual heat flux requirements are for melting loads, back and edge heat loss is not included.

Copyright 2003, American Society of Heating, Refrigerating and Air-Conditioning Engineers, Inc. www.ashrae.org.
 Reprinted by permission from ASHRAE 2003 Handbook-HVAC Applications.

STAIRS AND SLOPES (DRAINAGE) - APPENDIX C

Section thru stairs (side / plan view)

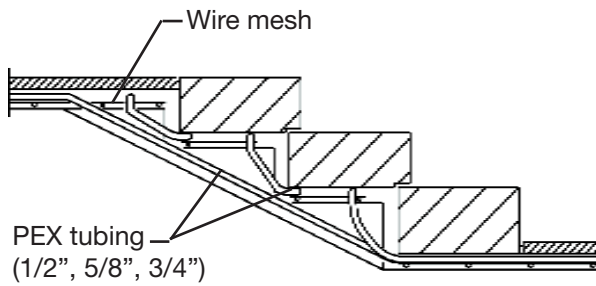

Serpentine Pattern

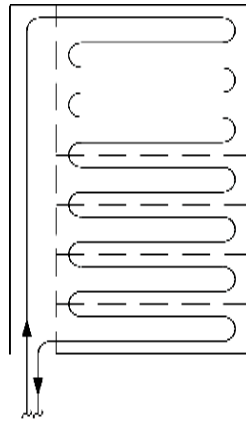

Reverse Return Pattern

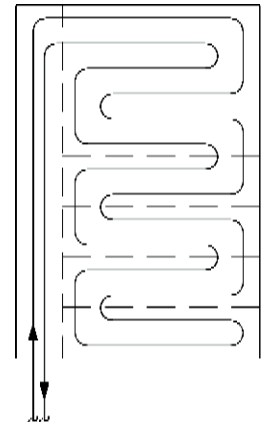

Note:
Reverse return pattern
recommended for level III
applications.

Section thru asphalt slope and drainage

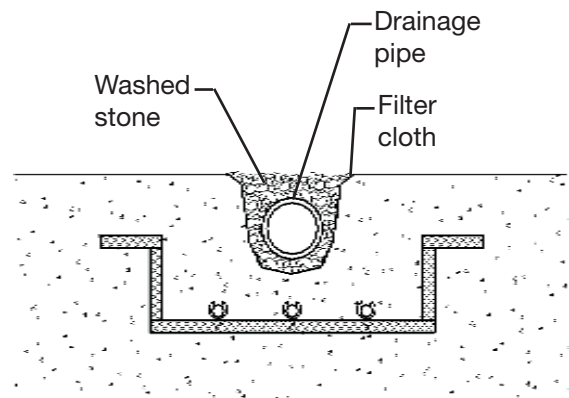
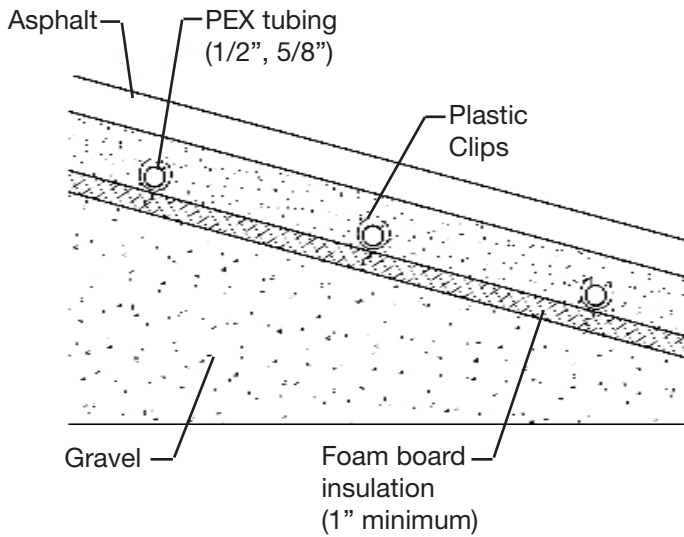

Note:
Appropriate surface drainage is
necessary for snow melting systems.

Note:
Drainage pipe should be heated as
shown or be installed below the frost
line.

PENETRATING JOINTS - APPENDIX D

Section thru fibrous expansion joint (typical)

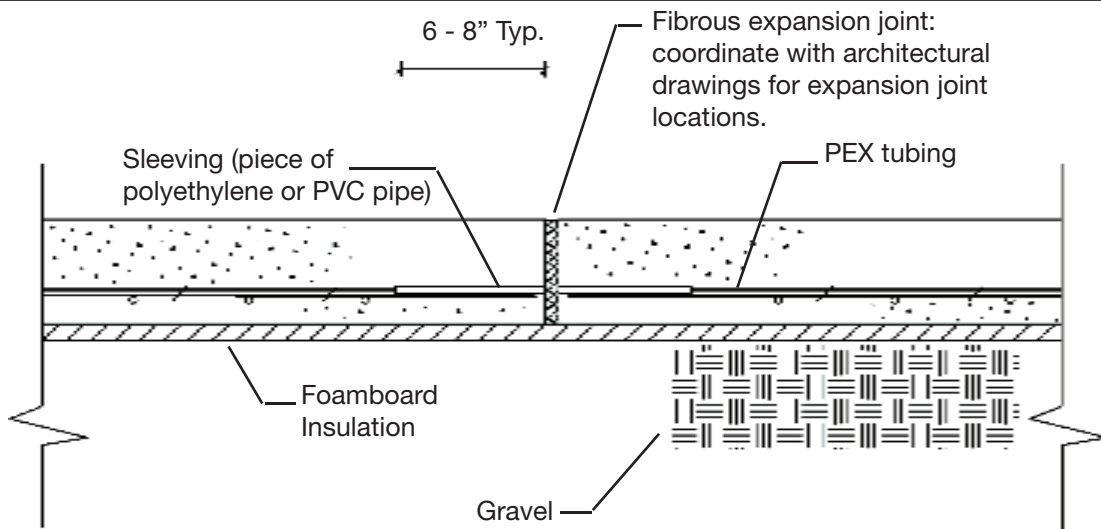

Section thru metal expansion joint (typical)

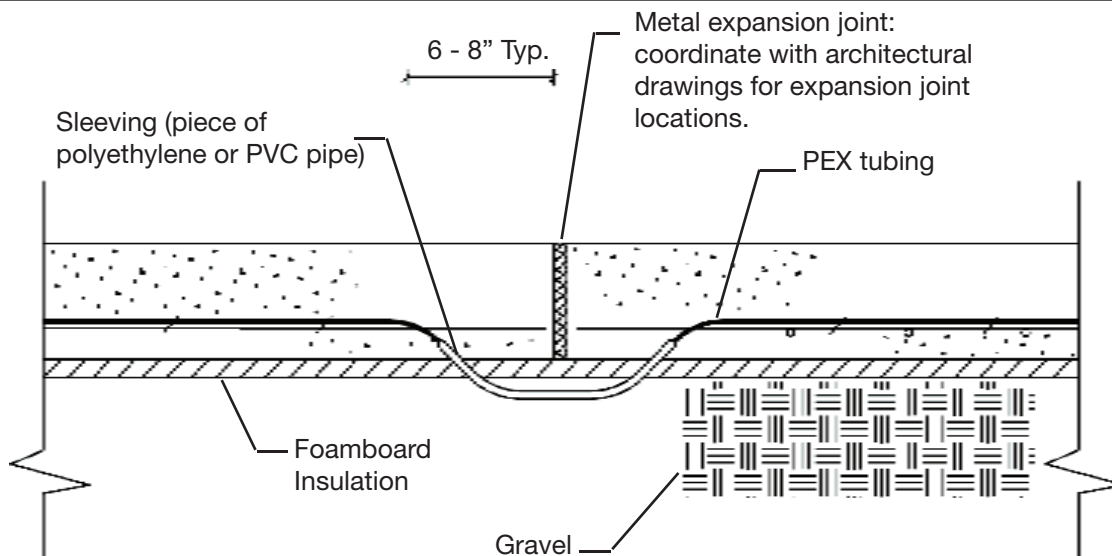

Section thru control joint (typical)

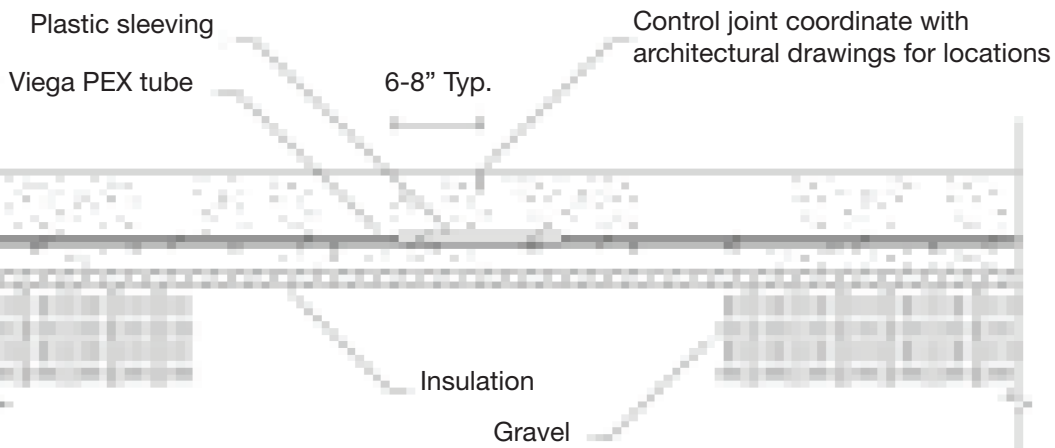

MAKING A COMPRESSION CONNECTION - APPENDIX E

Follow these steps each time you make a 5/16" - 5/8" compression connection.

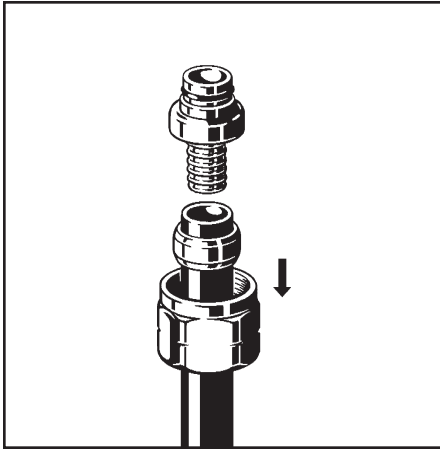

1. Square off end of tubing. Slide compression nut up tubing and slip brass ferrule over tubing.

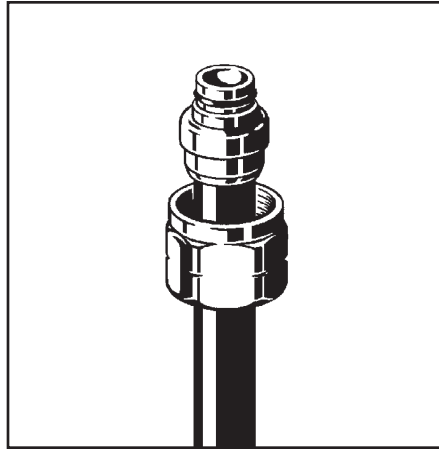

2. Slide tubing over end of SVC adapter, pushing it on fully until tubing is flush with shoulder of fitting.

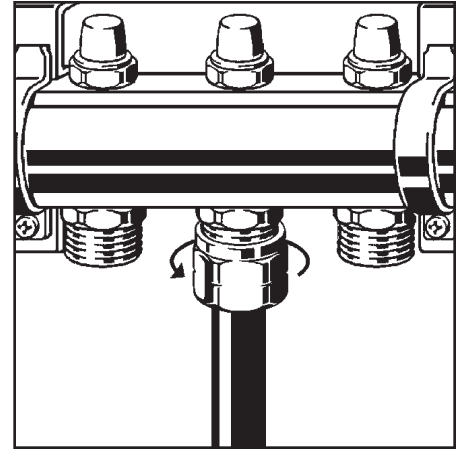

3. Insert SVC adapter into seat (manifold or other fitting) and tighten compression nut with wrench. Re-tighten compression nut slightly after 30 minutes.

Follow these steps each time you make a 3/4" compression connection.

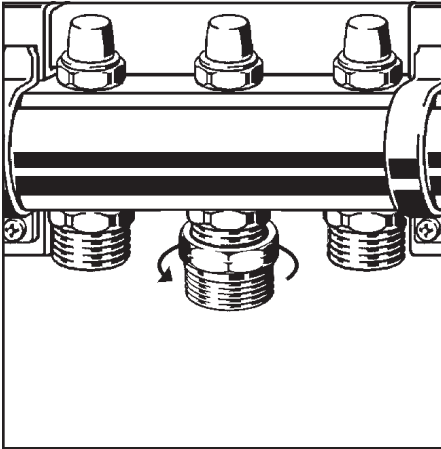

1. Tighten threaded adapter onto seat (manifold or other fitting).

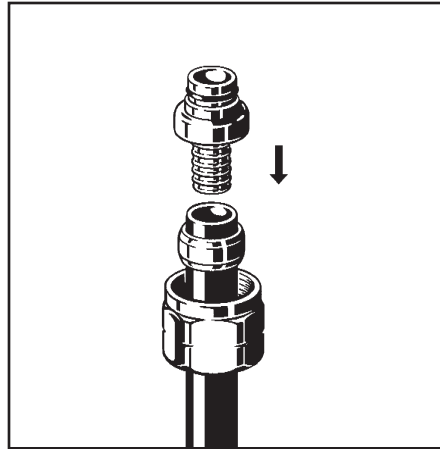

2. Square off tubing to proper length. Slide compression nut up tubing and slip brass ferrule over tubing.

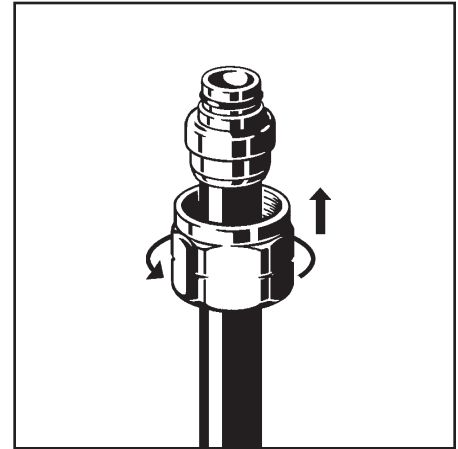

3. Slide tubing over end of SVC adapter, pushing it on fully until tubing is flush with shoulder of fitting.

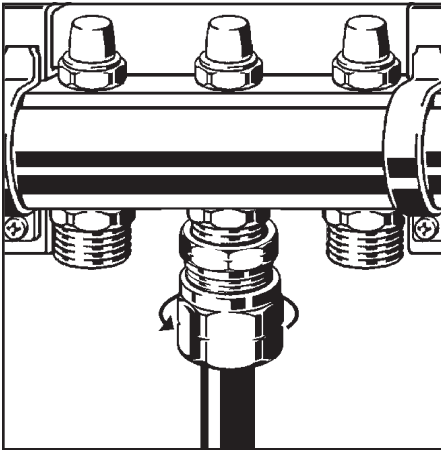

4. Insert SVC adapter into seat and tighten compression nut to adapter with wrench. Re-tighten compression nut slightly after 30 minutes.

MAKING A PRESS CONNECTION - APPENDIX F

FostaPex will hold a bend if necessary, is easy to use, has a professional appearance and will reduce installation time. Follow these steps each time you make a FostaPex connection.

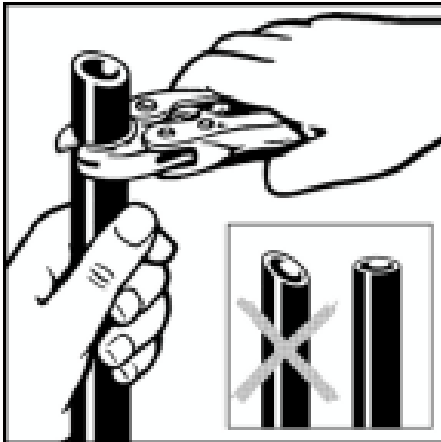

1. Square off tubing to proper length.

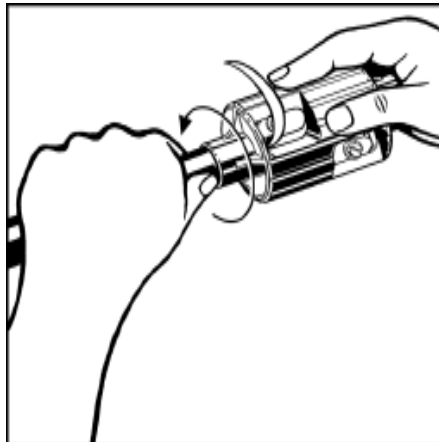

2. Insert FostaPex tubing into prep tool, push and turn until no more resistance is felt.

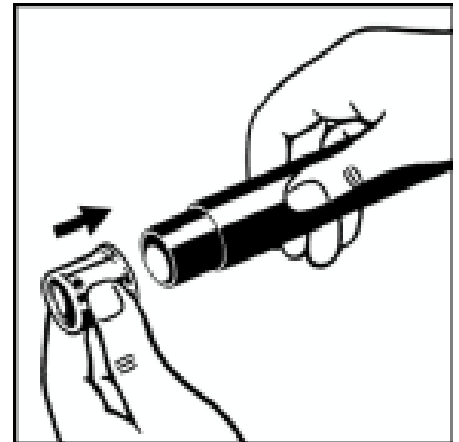

3. Slide press sleeve fully over end of tubing.

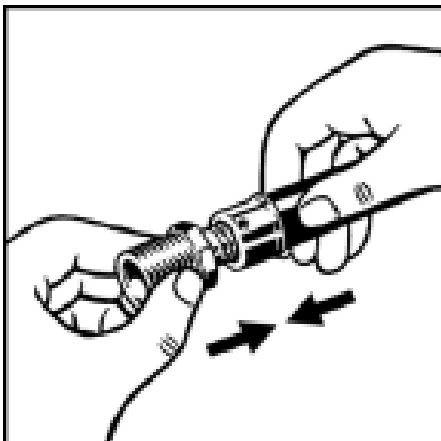

4. Insert press fitting into tubing and engage fully.

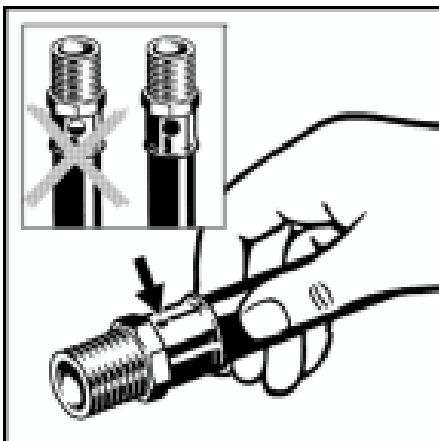

5. Check full tubing insertion at view hole of sleeve.

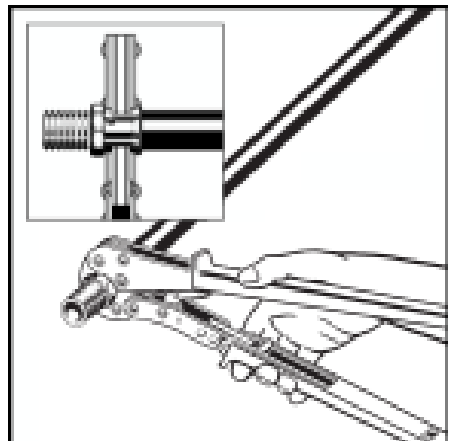

6. Position press tool perpendicular over press sleeve and close tool jaws to engage ratchet.

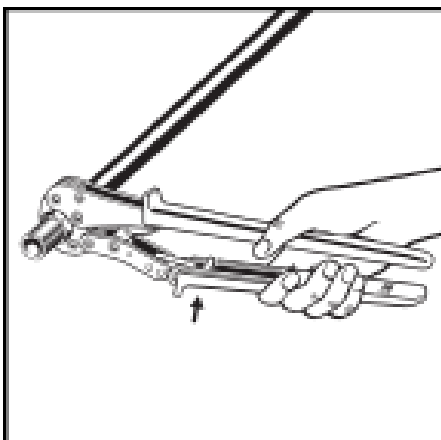

7. Close handles, utilizing trigger to reduce grip span if desired.

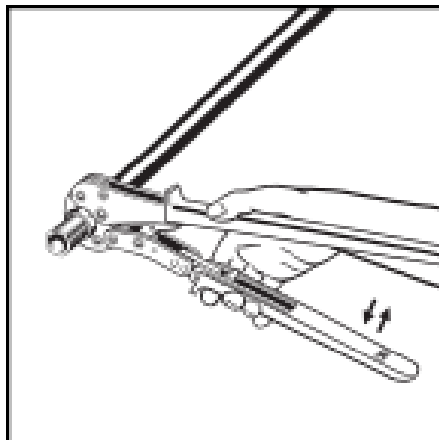

8. Extend handle and continue ratcheting until automatic tool release occurs at proper compression force.

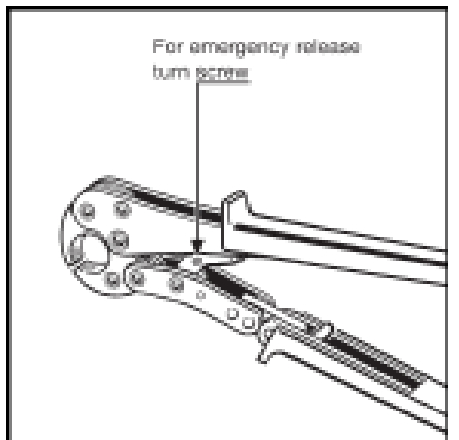

9. Warning: The connection is not leakproof when the tool has been opened by emergency release.

Selecting the Mixing Valve

Use the table below to select Mixing Valve based on the calculated Flow Rate.

Flow Rate (gpm)	3.5 - 5.5	5.5 - 9.5	9.5 - 14	14 - 22	22 - 34	34 - 55	55 - 95
Mixing Valve (inch)	3/4	1	1 1/4	1 1/2	2	2 1/2	3

Table G.1

Note: Valve size selection based on Viega's accepted pressure drop.

Determining the Pressure Drop

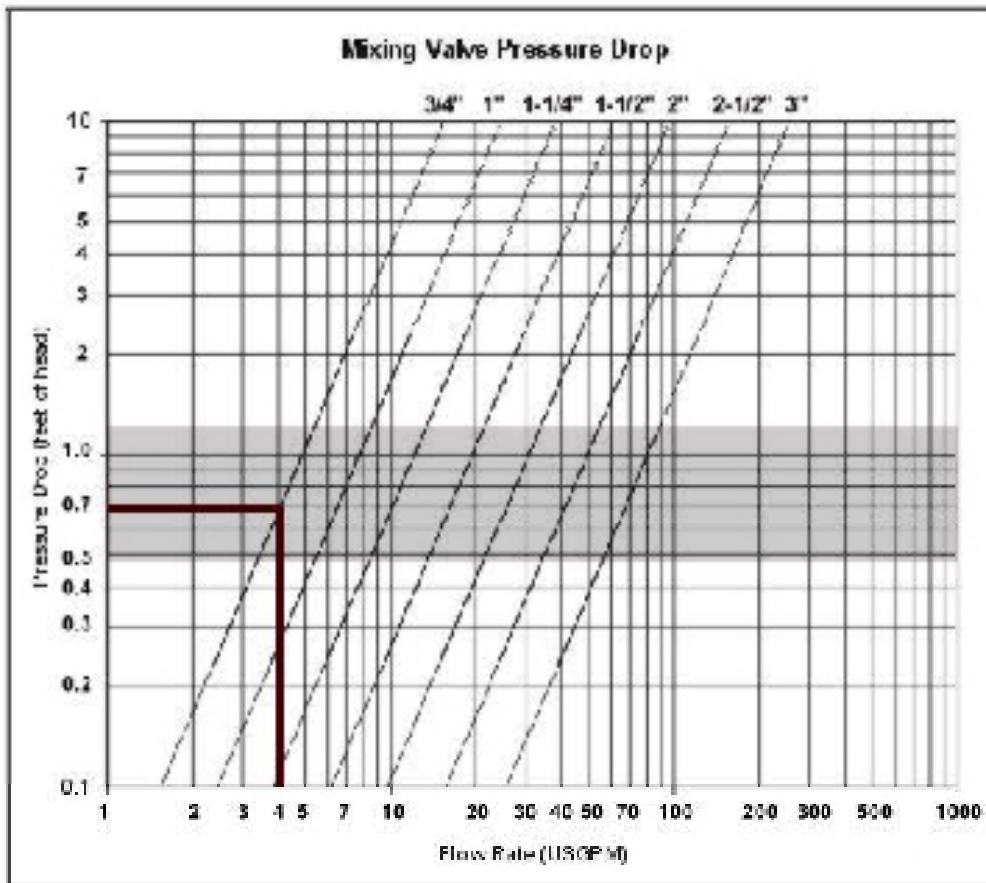

Figure G.1: Valve Sizing Chart

Note: Valve sizing chart applies to Viega's Mixing Valves.

Use the graphs to determine the pressure drop through the Mixing Valve.

Procedure:

1. Locate the desired flow rate for the valve on the horizontal axis.
2. Follow upwards until you reach the selected valve size in the grey shaded area.
3. Then move left to the vertical axis and read the pressure drop.

Example:

Flow Rate: 4 GPM

Selected Valve Size: 3/4 inch

Pressure Drop: 0.7 ft of hd

MAKING A MATERIAL LIST - APPENDIX H

Tubing and Fasteners Material Worksheet:

Use the first worksheet to select the amount of tubing and fasteners. Then select one worksheet below to create a piping and control material list. These charts are intended for conceptual purposes; there may be variations in each job.

Tubing (1/2" 5/8" 3/4")	Snow Melt Area (ft ²)	Multiplier	Estimated Amount
6" Spacing		2.2	
9" Spacing		1.5	
12" Spacing		1.1	

Fasteners*	Snow Melt Area (ft ²)	Multiplier	Estimated Amount
6" Spacing		1.1	
9" Spacing		.75	
12" Spacing		.55	

Piping and Controls Material Worksheets:

Basic snow melt package material worksheet:

Material	Quantity	Stock Code
Diverting Valve	1	20 001-003,041
Non-Electric Fixed Water Temp. Control	1	16 102-105
Basic Snow Melt Control	1	17 012
Heat Exchanger	1	22 006-008
1" Manifold, # outlets*	#*	15 012-022
Manifold Accessory Set	#*	15 023
Transformer 24V	1	18 008, 020

Advanced snow melt package material worksheet:

Material	Quantity	Stock Code
Mixing Valve	1	20 017-020, 025-028
Three Position Actuator	1	18 018, 019
Advanced Heating Control	1	16 014
Boiler Return Sensor (universal sensor)	1	16 018
Optional DHW Sensor (universal sensor)	1	16 018
Advanced Snow Melt Control	1	17 005
Heat Exchanger	1	22 006-008
1" Manifold, # outlets*	#*	15 012-022
Manifold Accessory Set	#*	15 023
Transformer 24V	1	18 008, 020

* Based on job requirements

viega

Viega... The global leader in plumbing and heating systems.

Professional products and service for professional contractors

**Rely on Viega North America for the most complete line of high tech/
high quality plumbing, heating and snow melting systems...plus the
most comprehensive customer support in the industry.**



Viega

301 N. Main, 9th Floor, Wichita, KS
67217

Phone: 800-976-9819

Fax: 800-976-9817

www.viega.com

service@viega.com