



The Torch Is Past  
(and so are welding and grooving)



The global leader  
in plumbing, heating  
and pipe joining systems



# The future of joining stainless steel pipe is here—Viega ProPress®

Put those welding torches away and pack up that old roll groover too. Now, there is a better way to connect stainless steel pipe—Viega press technology. ProPress is faster, safer and more consistent compared to traditional methods.

## Speed + Reliability = Results

- Speeds installation time with press connections completed in as little as five seconds.
- Consistent press connections mean water-tight and gas-tight joints every time.
- Patented Smart Connect feature identifies unpressed connections so they are not left behind.
- Thousands of professionals are using the ProPress system to improve installation time, avoid leaks and provide a professional-looking job.



# Here's the inside story on Viega press technology

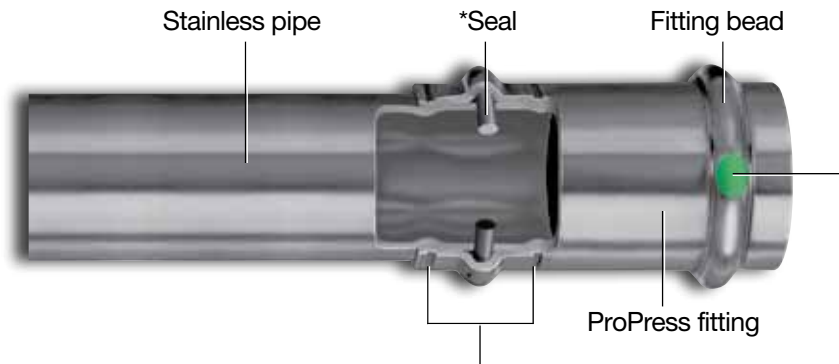

## Viega ProPress stainless 1/2" to 2" fittings

Unpressed connection with the Smart Connect feature allows liquids or air to pass by the sealing element during system test.

Connection is pressed in front of, on top of, and behind the seal, making a gas- or water-tight seal. The Smart Connect feature is sealed during pressing.

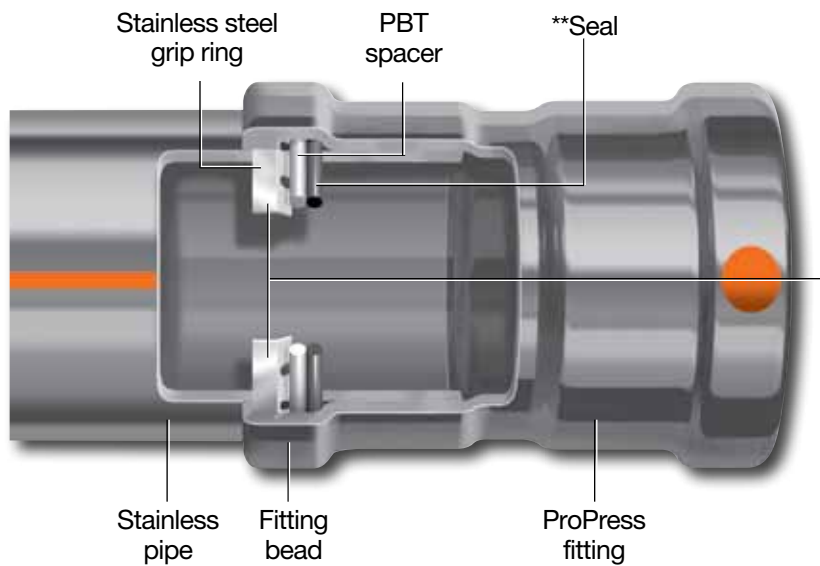

## Viega ProPress stainless 2 1/2" to 4" fittings

The stainless steel grip ring is pressed on top forcing the grip ring teeth against the pipe, making a secure connection.

### Available systems:

- Orange identifies Viega ProPress stainless steel 304.
- Green identifies Viega ProPress stainless steel 316.
- White identifies fittings with the FKM sealing element (304/316).

\* ZERO LEAD identifies Viega ProPress stainless steel 316 meets the lead-free requirements of California and Vermont law, effective January 1, 2010, as tested and listed against NSF-61, Annex G.

\*\* Viega ProPress in sizes 2-1/2" - 4" available with the choice of two sealing elements, EPDM and FKM.

# Only Viega fittings offer the Smart Connect® feature

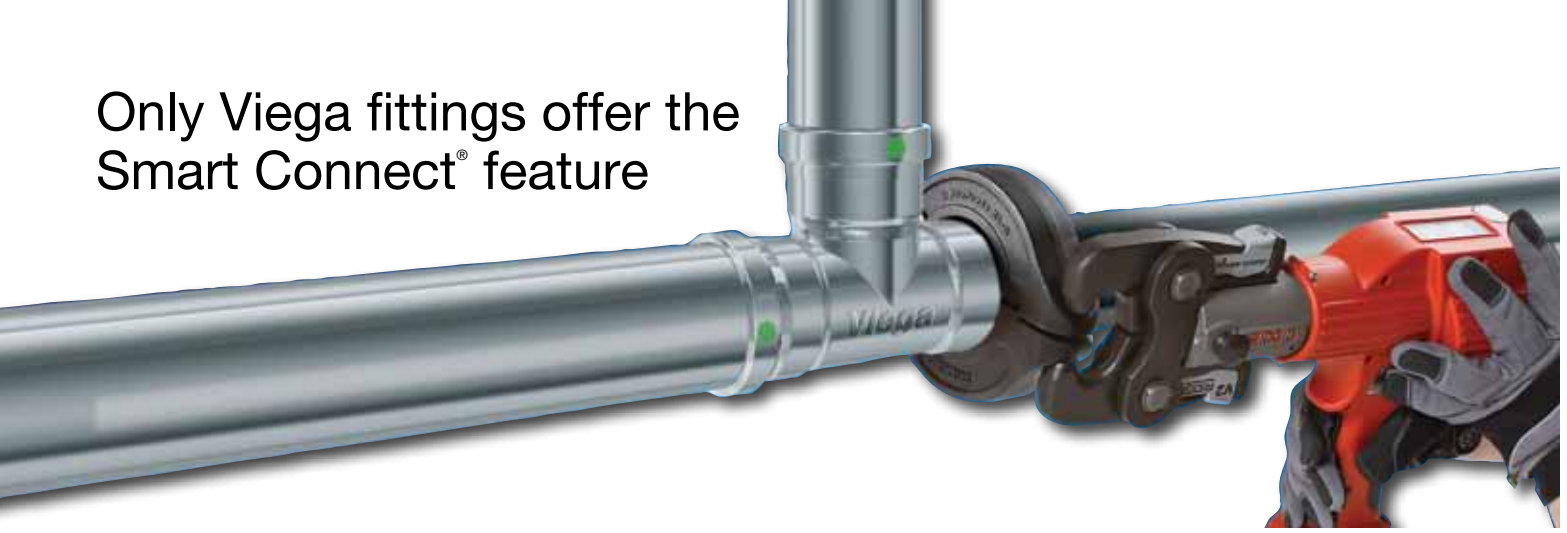

## Unpressed

Identify an unpressed connection during pressure testing when water or air flows past the sealing element.



## Pressing

Upon identification, the ProPress tool is used to press the fitting, making a permanent leak-proof connection.

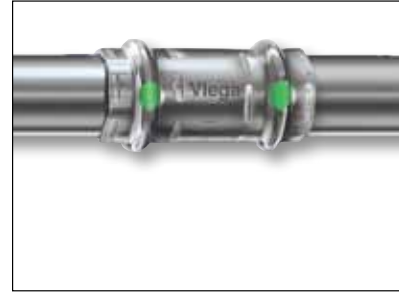

## Pressed

ProPress connections are fast, flameless and reliable.

## Patented 270° swivel

V2 actuator and pressing rings can rotate a full 270°. The swivel design increases flexibility in tight spaces.



## 304 and 316

## Two industrial grades ... one joining system

- System solution – pipe and fittings in sizes 1/2" to 4"
- Specialty fittings for instrumentation
- Sealing elements to meet application needs – EPDM, HNBR and FKM



## 316 ball valves

Available in sizes 1/2", 3/4", 1", 1 1/4", 1 1/2" and 2" equipped with the Smart Connect feature and lockable handles.

## New transition fittings

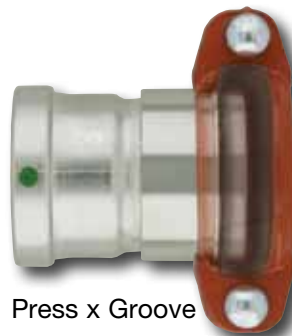

Press x Groove



Press x Weld

# Viega ProPress® stainless is the total package ... pipe, valves and fittings

The Viega ProPress system, pioneered in Europe by Viega, is sweeping the Americas. In commercial and industrial installations, Viega ProPress is the fastest, most reliable, flameless way to join stainless steel.



- Faster than welding or grooving
- Safer – no flame, no grinding
- Cleaner – no welding rods, smoke or cutting oils
- Complete – one source for pipe, valves and fittings
- Convenient – same tool and jaws for copper and stainless
- Adaptability – adapter and flanges to couple with any existing piping system
- More than 25 years of proven performance worldwide
- Highest quality stainless in two grades – 304 and 316
- Patented Smart Connect® feature – only Viega fittings have it
- Broad fitting selection size range – 1/2" to 4"
- Meets or exceeds industry standards
- Guaranteed reliability

Same set of tools and jaws for copper or stainless



# No one can press connect more applications in more industries than Viega ProPress®



## Viega ProPress specifications for stainless applications



Meets A269 Standard Specification for Seamless and Welded Austenitic Stainless Steel Tubing for General Service  
 Meets A312 Standard Specification for Seamless, Welded and Heavily Cold Worked Austenitic Stainless Steel Pipes  
 Meets ASTM A 403 Standard Specification for Wrought Austenitic Stainless Steel Piping Fittings  
 Meets ASTM A554 - 08a Standard Specification for Welded Stainless Steel Mechanical Tubing  
 Meets ASTM F 1476 Standard Specification for Performance of Gasketed Mechanical Couplings for Use in Piping Applications



Meets ASME B 31.1 Power Piping  
 Meets ASME B 31.3 Process Piping  
 Meets ASME B 31.9 Building Services Piping



Certified to NSF-61 Annex-G for potable water (316 alloy)



Approved for Service by the American Bureau of Shipping



Canadian Registration Number - 13492.5



For more information contact your  
 local Viega Account Manager or visit  
 our web site at [www.viega.com](http://www.viega.com).

724632\_PPS\_6PG\_BR\_611

**Viega**  
 301 N. Main, 9th floor, Wichita, KS 67202  
 Phone: 1-800-976-9819 Fax: 1-316-425-7618  
[www.viega.com](http://www.viega.com) • [insidesales@viega.com](mailto:insidesales@viega.com)

