

Product Instructions

PEX Press Connection

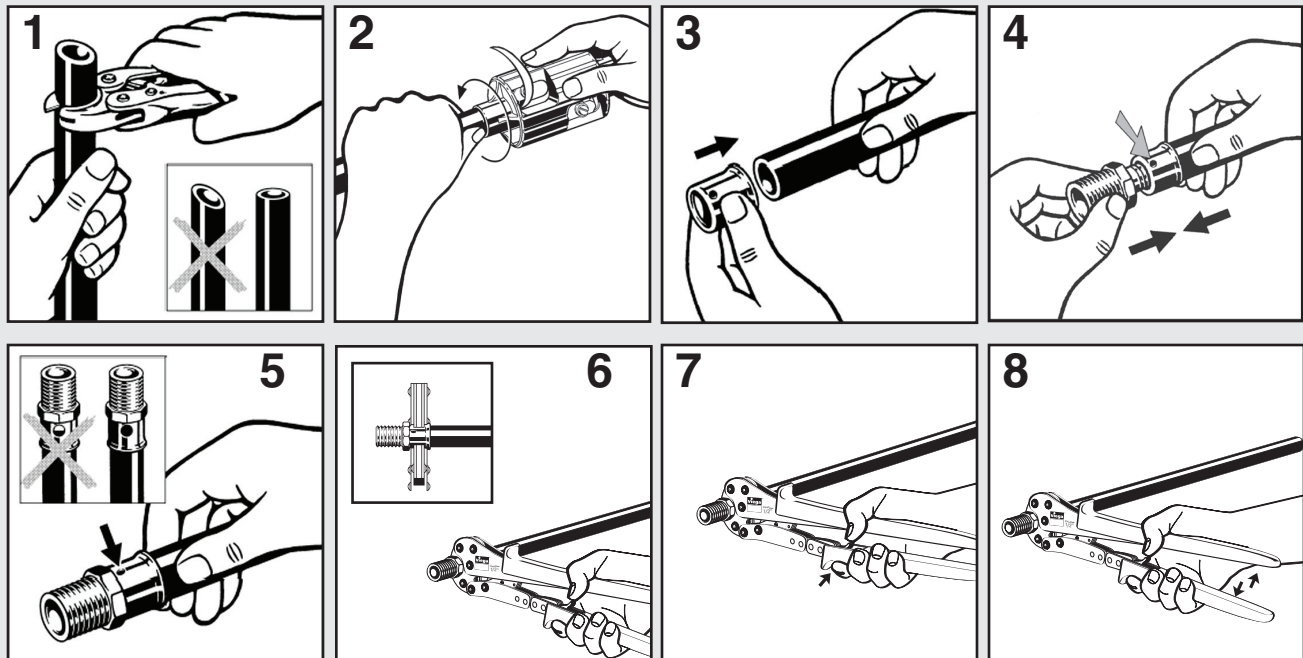

1. Square off tubing to proper length. Uneven, jagged or irregular cuts will produce unsatisfactory connections.
2. If using FostaPEX tubing, insert into prep tool, push and turn until no more resistance is felt. If using ViegaPEX, continue to step 3.
3. Slide press sleeve fully over end of tubing.
4. Insert press fitting into tubing and engage fully.
5. Check full tubing insertion at view hole of sleeve.
6. Position press tool perpendicular over press sleeve and close tool jaws to engage ratchet.
7. Close handles, utilizing trigger to reduce grip span if desired.
8. Extend handle and continue ratcheting until automatic tool release occurs at proper compression force.
9. **Warning:** The connection is not leakproof when the tool has been opened by emergency release.

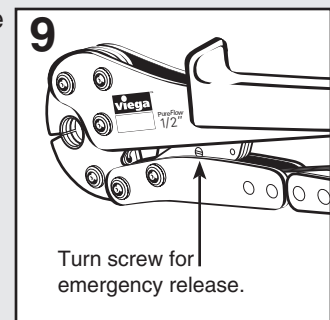

VIEGA • Viega... The global leader in plumbing and heating systems.

301 N. Main, Floor 9 • Wichita, KS 67202 • Ph: 877-Viega-NA • Fax: 800-976-9817 • E-Mail: service@viega.com • www.viega.com