

Product Instructions

viEGA

Viega Enhanced Mixing Station

Applications

The new Viega Enhanced Mixing Station provides fluid temperature modulation when connected to a variety of heat sources. The new station is equipped with an ECM motor pump that has a choice of seven settings. Through the use of these settings, it will enable the user to fine tune the pumps output to meet their specific needs. The use of this technology will allow for more efficient use of power resulting in energy savings. Boiler connections can be made with ProPress, PexPress or copper (male pipe end) for soldering. Red and blue caps on the ProPress ball valves clearly indicate system supply and return connections. A built in sensor well allows for easy mounting of control sensors. Compatible with The Basic Heating Control.

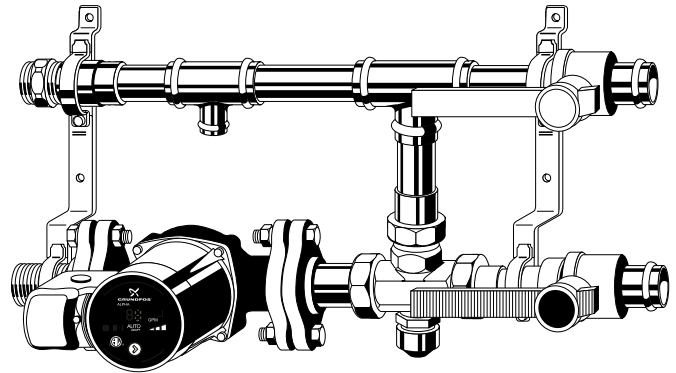

Features

- Power consumption reduced by 50% with the use of the permanently magnetized circulator motor present in this station
- Ready to hang, factory tested
- Ideal for direct connect or remote locations
- The diverting valve can be manually or electronically controlled
- Versatile boiler side connections
- Compatible with most heat sources

Specifications

Copper: Type "L" ASTM B88
Min Temp: 36°F
Max Temp: 230°F
Max Pressure: 100 psi
Max Glycol Mix: 50%

Description	Stock Code
ProPress 1" Ball Valves (2)	19688
ProPress 1" Tee	77412
ProPress 1" x 1/2" Tee	77432
ProPress 1" C x M NPT	77482
Sensor Well Set	12128
Diverting Valve	20002
Strap On Temp Gauge	15055
1" PEX Press x 1" Copper (Male)	67560

Viega... The global leader in plumbing, heating and pipe joining systems

301 N. Main, 9th Floor • Wichita, KS 67202 • Ph: 800-976-9819 • Fax: 316-425-7618 • www.viega.com

©2011, ProPress®, FostaPEX®, Seapress®, MegaPress®, MegaPressG® and Viega® are registered trademarks of Viega GmbH & Co. PureFlow®, Smart Connect®, Climate Panel®, Climate Mat®, Climate Trak®, MANABLOC®, Radiant Wizard®, S-no-Ice®, Snap Panel®, XL® and XL-C® are registered trademarks of Viega LLC. MiniBloc™, ProRadiant™, PolyAlloy™, SmartLoop™ and Zero Lead™ are trademarks of Viega LLC; GeoFusion™, ProPressG™ and ViegaPEX™ are trademarks of Viega GmbH & Co. KG.

Product Instructions

viega

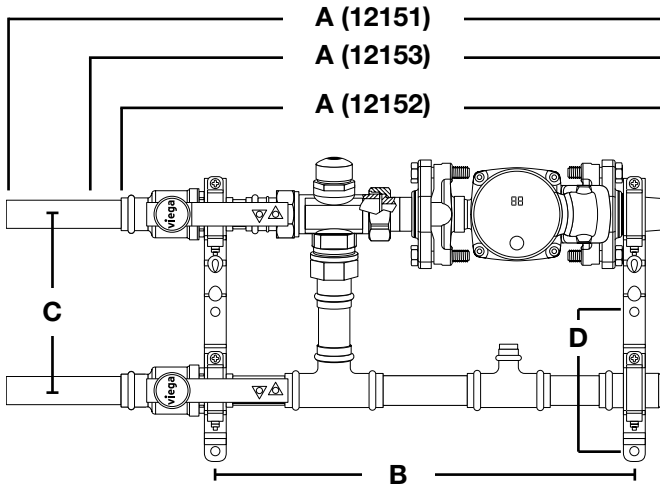
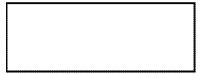

Dimensions*	
# Outlets	Mixing Station Stainless Manifold
1 outlet	N/A
2 outlets	28.96
3 outlets	30.96
4 outlets	32.96
5 outlets	34.86
6 outlets	36.86
7 outlets	38.86
8 outlets	40.76
9 outlets	42.76
10 outlets	44.76
11 outlets	46.66
12 outlets	48.66

* Dimensions based off stock code 12152

* When using stock code 12153 add .98"

* When using stock code 12151 add 4.04"

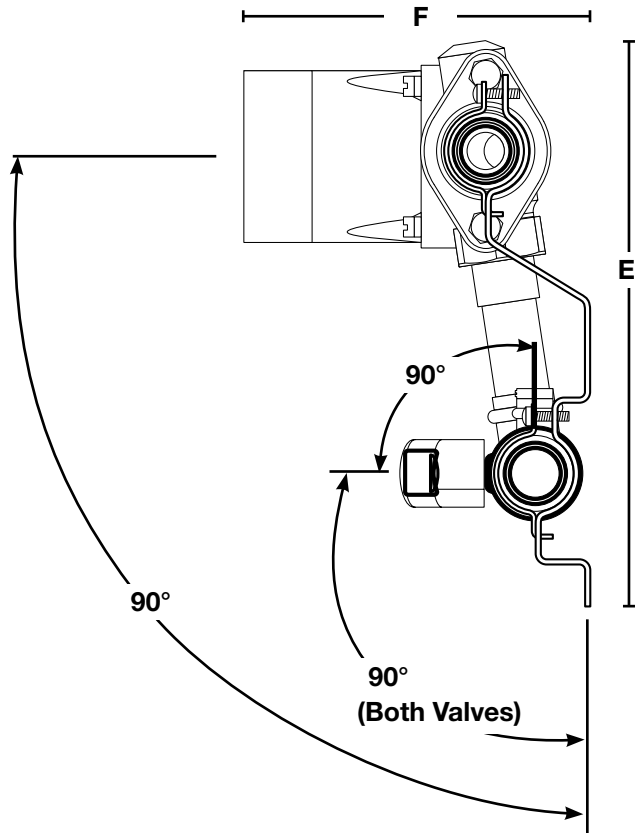

Stock Code	A (in)	B (in)	C (in)	D (in)	E (in)	F (in)
12151	24.79	16	6.69	5.31	11.72	7.39
12153	21.73	16	6.69	5.31	11.72	7.39
12152	20.75	16	6.69	5.31	11.72	7.39

Viega... The global leader in plumbing, heating and pipe joining systems

301 N. Main, 9th Floor • Wichita, KS 67202 • Ph: 800-976-9819 • Fax: 316-425-7618 • www.viega.com

©2011, ProPress®, FostaPEX®, Seapress®, MegaPress®, MegaPressG® and Viega® are registered trademarks of Viega GmbH & Co. PureFlow®, Smart Connect®, Climate Panel®, Climate Mat®, Climate Trak®, MANABLOC®, Radiant Wizard®, S-no-ice®, Snap Panel®, XL® and XL-C® are registered trademarks of Viega LLC. MiniBloc™, ProRadiant™, PolyAlloy™, SmartLoop™ and Zero Lead™ are trademarks of Viega LLC; GeoFusion™, ProPressG™ and ViegaPEX™ are trademarks of Viega GmbH & Co. KG.

Product Instructions

viega

Performance* and operation mode selection

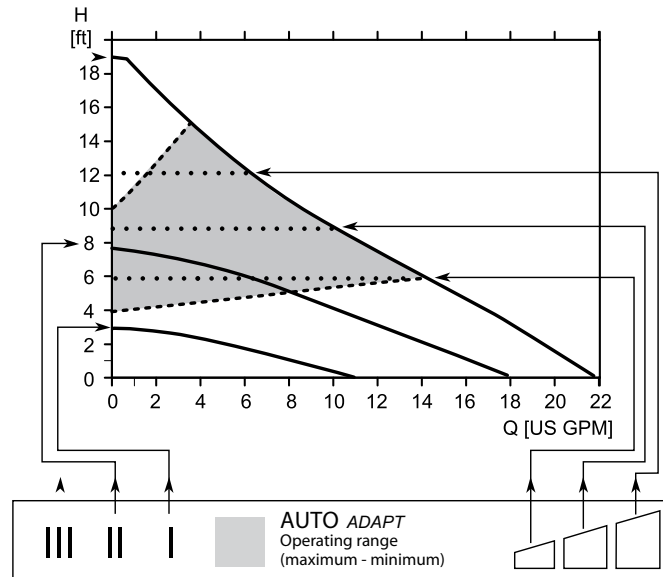

*Hydraulic performance without check valve

Pos. Description



- Push-button for selection of pump setting
- Every time the push-button is pressed, the circulator setting is changed

High Fixed Speed

- III • Runs at a constant speed and consequently on a constant curve. In Speed III, the pump is set on the maximum curve under all operating conditions. Quick Vent of the pump can be obtained by setting the pump to Speed III for a short period.

Medium Fixed Speed

- II • Runs at a constant speed and consequently on a constant curve. In Speed II, the pump is set on the medium curve under all operating conditions.

Low Fixed Speed

- I • Runs at a constant speed and consequently on a constant curve. In Speed I, the pump is set on the minimum curve under all operating conditions.

Constant Pressure I



- The duty point of the pump will move left and right along the lowest constant-pressure curve depending on water demand in the system. The pump head (pressure) is kept constant, irrespective of the water demand.

Constant Pressure II



- The duty point of the pump will move left and right along the middle constant-pressure curve depending on water demand in the system. The pump head (pressure) is kept constant, irrespective of the water demand.

Constant Pressure III



- The duty point of the pump will move left and right along the highest constant-pressure curve depending on water demand in the system. The pump head (pressure) is kept constant, irrespective of the water demand.

AutoADAPT (Factory Setting)



- This function controls the pump performance automatically within the defined performance range (shaded area). AutoADAPT will adjust the pump performance to system demands over time.

Viega... The global leader in plumbing, heating and pipe joining systems

301 N. Main, 9th Floor • Wichita, KS 67202 • Ph: 800-976-9819 • Fax: 316-425-7618 • www.viega.com

©2011, ProPress®, FostaPEX®, Seapress®, MegaPress®, MegaPressG® and Viega® are registered trademarks of Viega GmbH & Co. PureFlow®, Smart Connect®, Climate Panel®, Climate Mat®, Climate Trak®, MANABLOC®, Radiant Wizard®, S-no-ice®, Snap Panel®, XL® and XL-C® are registered trademarks of Viega LLC. MiniBloc™, ProRadiant™, PolyAlloy™, SmartLoop™ and Zero Lead™ are trademarks of Viega LLC; GeoFusion™, ProPressG™ and ViegaPEX™ are trademarks of Viega GmbH & Co. KG.

Product Instructions

viega

Terminal Box Models

Wiring procedure:

1. Loosen terminal box screw from terminal box cover.
2. Utilize either conduit port for wiring entrance.
3. Gently push open wiring terminal levers (L-N-G) for wiring installation.
4. Slide terminal box cover over terminal box body.
5. Tighten terminal box screw Phillips #1 (5 in-lbs).
6. Apply power.
7. Lights on the control panel indicate electrical supply has been switched on.

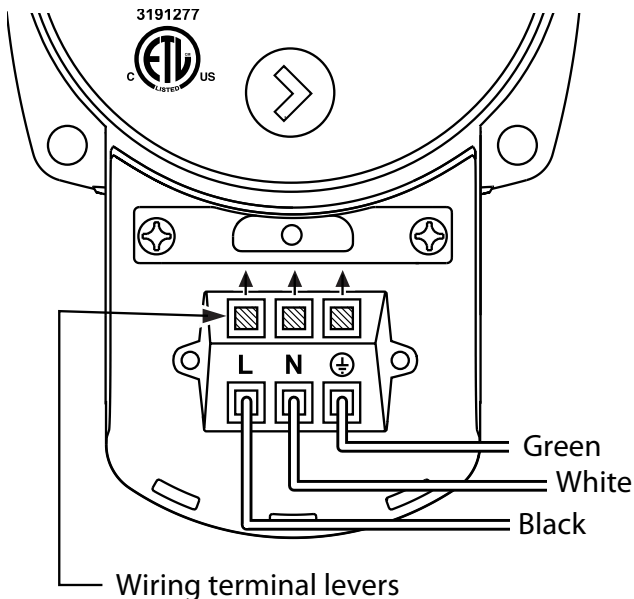

Note: Circulator must be properly grounded.

Nameplate

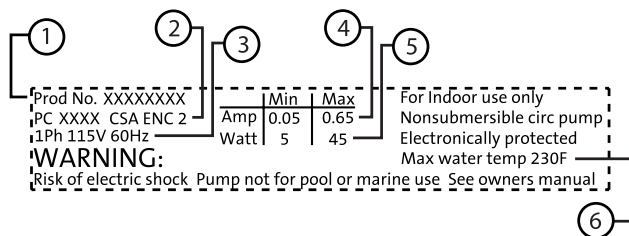

Pos. Description

- | Pos. | Description |
|------|---|
| 1 | Product Number |
| 2 | Production Code: <ul style="list-style-type: none"> • 1st and 2nd figures = year • 3rd and 4th figures = week |
| 3 | Voltage (V): |
| 4 | Rated current (A): <ul style="list-style-type: none"> • Min.: Minimum Current (A) • Max.: Maximum Current (A) |
| 5 | Input power (W): <ul style="list-style-type: none"> • Min.: Minimum Power (W) • Max.: Maximum Power (W) |
| 6 | Max. fluid temperature (F) |

Control Display

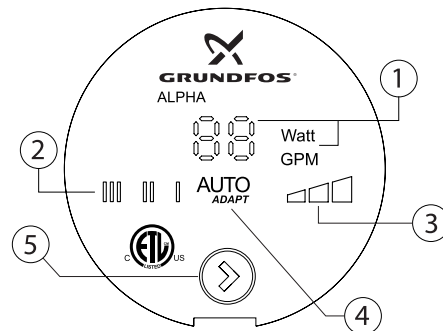

Pos. Description

- | Pos. | Description |
|------|---|
| 1 | LED showing Watt or flow indicator |
| 2 | LED indicating fixed speed |
| 3 | LED indicating constant pressure |
| 4 | LED AutoADAPT |
| 5 | Push-button for selection of pump setting |

Lockout condition

Identified by two horizontal dashes on the display of the circulator (--) This can be caused by:

1. Air
2. locked rotor
3. over/under voltage.

Identify and repair the problem. To clear the lockout condition: Disconnect power to the unit for 3 minutes and then re-power the circulator.

Viega... The global leader in plumbing, heating and pipe joining systems

301 N. Main, 9th Floor • Wichita, KS 67202 • Ph: 800-976-9819 • Fax: 316-425-7618 • www.viega.com

©2011, ProPress®, FostaPEX®, Seapress®, MegaPress®, MegaPressG® and Viega® are registered trademarks of Viega GmbH & Co. PureFlow®, Smart Connect®, Climate Panel®, Climate Mat®, Climate Trak®, MANABLOC®, Radiant Wizard®, S-no-ice®, Snap Panel®, XL® and XL-C® are registered trademarks of Viega LLC. MiniBloc™, ProRadiant™, PolyAlloy™, SmartLoop™ and Zero Lead™ are trademarks of Viega LLC. GeoFusion™, ProPressG™ and ViegaPEX™ are trademarks of Viega GmbH & Co. KG.

Product Instructions

viEGA

Technical Data

Supply voltage: 1x115V +/-10 %, 60Hz.

Motor protection: The pump requires no external motor protection.

Enclosure class: Indoor use only, IP42.
CSA Enclosure Type 2.

Insulation class: F.

Relative air humidity: Maximum 95 %.

Maximum discharge pressure: 150 psi (10.34 bar).

Inlet pressure:

Liquid temperature	Min. inlet pressure
167 °F (75 °C)	0.75 psi (0.05 bar)
194 °F (90 °C)	4.06 psi (0.28 bar)
230 °F (110 °C)	15.7 psi (1.08 bar)

Sound pressure level: 43 dB (A).

To avoid condensation in the control box and stator, the liquid temperature must always be higher than the ambient temperature.

Ambient temperature [°F (°C)]	Liquid temperature	
	Min. [°F (°C)]	Max. [°F (°C)]
+32 °F (0 °C)	+36 °F (+2 °C)	+230 °F (+110 °C)
+50 °F (+10 °C)	+50 °F (+10 °C)	+230 °F (+110 °C)
+68 °F (+20 °C)	+68 °F (+20 °C)	+230 °F (+110 °C)
+86 °F (+30 °C)	+86 °F (+30 °C)	+230 °F (+110 °C)
+95 °F (+35 °C)	+95 °F (+35 °C)	+194 °F (+90 °C)
+104 °F (+40 °C)	+104 °F (+40 °C)	+158 °F (+70 °C)

Maximum glycol concentrations:

50 % glycol @ 36 °F (2 °C).

Hydraulic performance change can be expected.

Watt readings: Accuracy +/-1 Watt.

Flow indicator:

Provides a relative indication of flow — should not be used in lieu of a flow meter.

Check valve:

Use of check valve may reduce pump hydraulic performance (up to -10%). Use check valve in parallel pumping applications.

Curve conditions:





Test liquid: Airless water.

Curves apply to a density of 983.2 kg/m³ and a liquid temperature of +140 °F (+60 °C).

All curves show average values and should not be used as guarantee curves. If a specific minimum performance is required, individual measurements must be made.

Curves apply to a kinematic viscosity of 0.474 cSt.

Approximate power usage:

Speed Setting		Min.	Max.
High fixed speed	III	39W	45W
Medium fixed speed	II	15W	30W
Low fixed speed	I	5W	8W
Constant pressure		8W	45W
Constant pressure		14W	45W
Constant pressure		22W	45W
AutoADAPT		5W	45W

ViEGA... The global leader in plumbing, heating and pipe joining systems

301 N. Main, 9th Floor • Wichita, KS 67202 • Ph: 800-976-9819 • Fax: 316-425-7618 • www.viega.com

©2011, ProPress®, FostaPEX®, Seapress®, MegaPress®, MegaPressG® and ViEGA® are registered trademarks of ViEGA GmbH & Co. PureFlow®, Smart Connect®, Climate Panel®, Climate Mat®, Climate Trak®, MANABLOC®, Radiant Wizard®, S-no-Ice®, Snap Panel®, XL® and XL-C® are registered trademarks of ViEGA LLC. MiniBloc™, ProRadiant™, PolyAlloy™, SmartLoop™ and Zero Lead™ are trademarks of ViEGA LLC; GeoFusion™, ProPressG™ and ViEGAPEX™ are trademarks of ViEGA GmbH & Co. KG.

Product Instructions

viega

Installation

Mounting the Mixing Station

The Mixing Station comes factory tested and mounted on brackets making it ready to hang. Simply install four pan head screws, or wood screws with washers, into the predrilled holes in the mounting brackets. See Dimensions on page 2 for mounting holes and spacing. The station brackets have the same offset as the Manifolds, making direct connecting simple. The station can also be used as a centrally located control center for remote manifolds instead of direct connecting to manifolds. Use the 1" M NPT adapters at the end of the station to connect to Viega PEX Press fittings and ViegaPEX Barrier or FostaPEX tubing to remote manifolds in different areas of the job.

Connecting The Enhanced Mixing Station to a primary loop (boiler loop)

The Enhanced mixing station is available in three boiler side connections:

1. Copper (male) stock code number 12151 -- Copper (male) when soldering stations to boiler loop (primary loop).
2. ProPress stock code number 12152 -- ProPress connections when connecting station to boiler loop (primary loop).
3. PEX Press stock code number 12153 -- ViegaPEX Barrier or FostaPEX when connecting the station to boiler loop (primary loop).

Note: When using Copper (male) stations be aware that the isolation ball valve is a ProPress connection and needs to be protected when soldering. The Copper (male) length is in accordance with ProPress distance requirements for soldering, but take additional steps to be sure press connection is protected to prevent the sealing element from being damaged. A damp rag wrapped around the ProPress Ball Valve will protect the sealing element from overheating.

Connecting The Enhanced Mixing Station to Stainless Manifolds

Connecting the The Enhanced Mixing Station to Stainless Manifolds

Use Teflon tape to wrap the 1" M NPT mixing station adapter. Wrap tape in the same direction as tightening the adapter. Once taped, apply a small amount of pipe dope on top of the tape for first few threads. Connect the supplied 1-1/4" x 1" Brass Bushing to the 1" M NPT adapter. Use the 1-1/4" threads to connect the 1-1/4" union connection to the Enhanced Mixing Station. Do this for both supply and return manifolds. Supply and return manifolds are identified by the red (supply) and blue (return) caps. The Mixing Station is identified by the red cap ProPress Ball Valve (supply) and blue cap ProPress Ball Valve (return) caps.

Sensor Well

The sensor well is designed to house the supply temperature sensor for the Basic Heating Control. Align the flat side of the sensor perpendicular with the set screw. Tighten screw with flathead screwdriver (thermostat screwdriver) to secure the sensor in the well.

Viega... The global leader in plumbing, heating and pipe joining systems

301 N. Main, 9th Floor • Wichita, KS 67202 • Ph: 800-976-9819 • Fax: 316-425-7618 • www.viega.com

©2011, ProPress®, FostaPEX®, Seapress®, MegaPress®, MegaPressG® and Viega® are registered trademarks of Viega GmbH & Co. PureFlow®, Smart Connect®, Climate Panel®, Climate Mat®, Climate Trak®, MANABLOC®, Radiant Wizard®, S-no-Ice®, Snap Panel®, XL® and XL-C® are registered trademarks of Viega LLC. MiniBloc™, ProRadiant™, PolyAlloy™, SmartLoop™ and Zero Lead™ are trademarks of Viega LLC. GeoFusion™, ProPressG™ and ViegaPEX™ are trademarks of Viega GmbH & Co. KG.

Product Instructions

viEGA

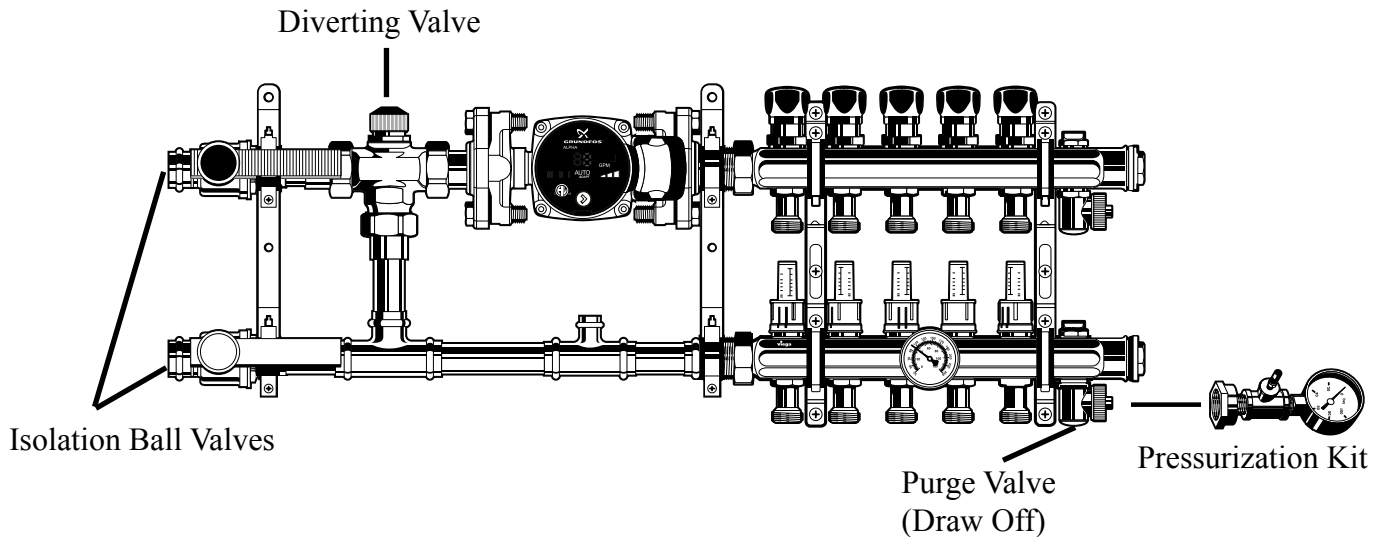

Pressure Testing

Before the finish floor is installed and during a concrete pour the radiant system must be pressure tested. Air or water may be used as the medium. The following procedure is recommended by Viega. Check with the local authority having jurisdiction for additional test requirements.

1. Double check all connections to manifold to ensure tightness
2. Connect manifold pressurization kit to the purge valve (draw-off) on the return manifold. The purge valve on Stainless Manifolds are found in a similar location, but are built into the manifold header
3. Close isolation ball valves on the Mixing Station
4. Open Diverting Valve (turn grey cap counter clockwise to open)
5. Open all circuits on manifold
6. Pressurize the system to 100 psi for at least 1 hour

Air as the medium: use a bicycle pump or compressor. Viega's Pressurization Kit comes equipped with a schrader valve for pressurizing with air.

Water as the medium: open the isolation valves to fill and pressurize. Or, backfill using a garden hose with a washing machine hose attached to it so there is a hose x hose connection. Attach one end of the hose to the purge valve on the station and the other end of the hose to a hose bib, wall hydrant, or sillcock. This method is limited to city or well water pressure.

The system should hold the 100 psi for a minimum of 1 hour.*

NOTE: Maintain pressure during the installation of the finish floor to simplify leak detection. Note what the pressure is and check occasionally. If pressure drops, some investigating may be necessary. If the tubing is damaged, repair necessary section with a compression coupling.

TIP: If air test leaks more than once, test with water

*Minor drop in pressure can be a result of change in ambient temperature

Viega... The global leader in plumbing, heating and pipe joining systems

301 N. Main, 9th Floor • Wichita, KS 67202 • Ph: 800-976-9819 • Fax: 316-425-7618 • www.viega.com

©2011, ProPress®, FostaPEX®, Seapress®, MegaPress®, MegaPressG® and Viega® are registered trademarks of Viega GmbH & Co. PureFlow®, Smart Connect®, Climate Panel®, Climate Mat®, Climate Trak®, MANABLOC®, Radiant Wizard®, S-no-Ice®, Snap Panel®, XL® and XL-C® are registered trademarks of Viega LLC. MiniBloc™, ProRadiant™, PolyAlloy™, SmartLoop™ and Zero Lead™ are trademarks of Viega LLC; GeoFusion™, ProPressG™ and ViegaPEX™ are trademarks of Viega GmbH & Co. KG.

Product Instructions

viEGA

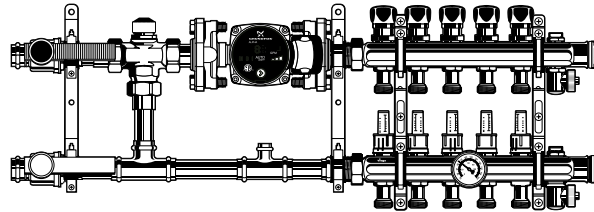

Purging

Assuming that the heat source is already filled and purged:

Stainless Balancing Manifolds

Supply manifold: remove black caps to expose balancing valve. Use a 5mm allen wrench to open and close each circuit.
Return manifold: use each blue return cap to open and close each circuit.

Stainless Balancing and Flow Meter Manifolds

Supply manifold: lift locking cap and turn flow meters to open and close each circuit.
Return manifold: use each blue return cap to open and close each circuit..

1. Open supply isolation valve and all supply and return circuits to fill Mixing Station and manifold from the heat source
2. Connect drain hose (i.e. washing machine hose) to hose thread on the return manifold purge valve (draw-off)
3. Open purge valve (draw-off)
4. Close supply isolation valve and open return isolation valve. Purge the return line
5. Spin grey cap on Diverting Valve so the valve position is about 50% open
6. Close return isolation valve
7. Open the supply isolation valve
8. Close supply and return balancing valves on manifold
9. Open the supply manifold circuit and return manifold circuit that is furthest from the draw-off; push air through the entire circuit and out the draw-off eliminating air from that circuit
10. Once the air has been purged, close the supply and return circuits
11. Move onto the next circuit; watch the pressure gauge on the heat source;* do this for each circuit: open, purge, close
12. Once purging is complete, close draw-off and disconnect hose; open circuits and balance if necessary
13. Open the return isolation valve
14. Set safety high limit on Diverting Valve (optional)

NOTE: Purging time and the amount of discharge may vary. Systems may need to be purged more than once. Air in the system may prevent flow and heat transfer. If system is purged in the future it is important to open the Diverting Valve fully and to power down the circulator.

* Tip: Purging is easier when using more than operating pressure to push air out using a fastfill component to boost pressure to 20-25 psi. Pressure must be kept below the Safety Pressure Relief Valve limit (commonly 30-50psi).
Another tip: use a 5 gallon bucket with the hose submerged under the water level. Use the air bubbles floating to the surface as a guide. Once the air bubbles have stopped, purge a few seconds more to ensure the line is free of air. Watch the pressure in the system CAREFULLY to avoid discharging the Safety Relief Valve.

ViEGA... The global leader in plumbing, heating and pipe joining systems

301 N. Main, 9th Floor • Wichita, KS 67202 • Ph: 800-976-9819 • Fax: 316-425-7618 • www.viega.com

©2011, ProPress®, FostaPEX®, Seapress®, MegaPress®, MegaPressG® and ViEGA® are registered trademarks of ViEGA GmbH & Co. PureFlow®, Smart Connect®, Climate Panel®, Climate Mat®, Climate Trak®, MANABLOC®, Radiant Wizard®, S-no-Ice®, Snap Panel®, XL® and XL-C® are registered trademarks of ViEGA LLC. MiniBloc™, ProRadiant™, PolyAlloy™, SmartLoop™ and Zero Lead™ are trademarks of ViEGA LLC; GeoFusion™, ProPressG™ and ViEGAPEX™ are trademarks of ViEGA GmbH & Co. KG.

Product Instructions

viEGA

Setting Safety High Limit

The Mixing Station is provided with a pre-installed temperature safety high limit feature that allows a maximum fluid temperature to be set. This feature should be used when purging is complete and system is fully operational. To use this feature follow the steps below:

If radiant system is being serviced, the safety high limit must be turned off for purging. Reset after purging.

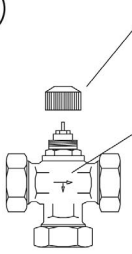
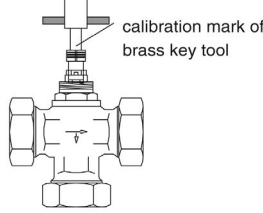
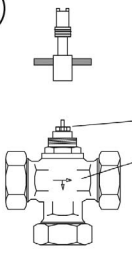
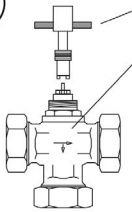
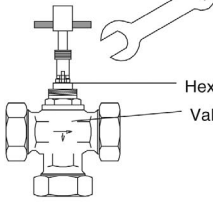
<p>1</p>  <p>Grey Cap (This cap can be used to adjust the water temperature manually.)</p> <p>Valve Body</p> <p>Remove grey plastic cap from valve body.</p>	<p>4</p> <p>Note: This calibration must be done with the boiler at its highest temperature, the circulator running and all zones open.</p>  <p>calibration mark of brass key tool</p>
<p>2</p>  <p>Hex Lock Nut</p> <p>Valve Body</p> <p>Loosen up hex lock nut with brass key tool.</p>	<p>Turn adjustment screw further clockwise until desired supply water temperature is obtained and count quarter turns for reference. This has to be done carefully and slowly because each quarter turn of the adjustment screw will result in approximately 15°F temperature reduction. Wait until desired water temperature stays consistent.</p>
<p>3</p>  <p>Brass Key Tool</p> <p>Valve Body</p> <p>Use opposite side of brass key tool and turn inner adjustment screw (slotted) in clockwise until valve spring resistance is felt.</p> <p>To lower water temperature turn key clockwise; turn counterclockwise to raise it.</p>	<p>5</p>  <p>Hex Head Nut</p> <p>Valve Body</p> <p>Tighten hex lock nut with wrench. Do not overtighten! To secure high limit adjustment, hold slotted adjustment screw with brass key while tightening lock nut.</p>

ViEGA... The global leader in plumbing, heating and pipe joining systems

301 N. Main, 9th Floor • Wichita, KS 67202 • Ph: 800-976-9819 • Fax: 316-425-7618 • www.viega.com

©2011, ProPress®, FostaPEX®, Seapress®, MegaPress®, MegaPressG® and ViEGA® are registered trademarks of ViEGA GmbH & Co. PureFlow®, Smart Connect®, Climate Panel®, Climate Mat®, Climate Trak®, MANABLOC®, Radiant Wizard®, S-no-Ice®, Snap Panel®, XL® and XL-C® are registered trademarks of ViEGA LLC. MiniBloc™, ProRadiant™, PolyAlloy™, SmartLoop™ and Zero Lead™ are trademarks of ViEGA LLC; GeoFusion™, ProPressG™ and ViEGAPEX™ are trademarks of ViEGA GmbH & Co. KG.

Product Instructions



Enhanced Mixing Station Piping Schematic

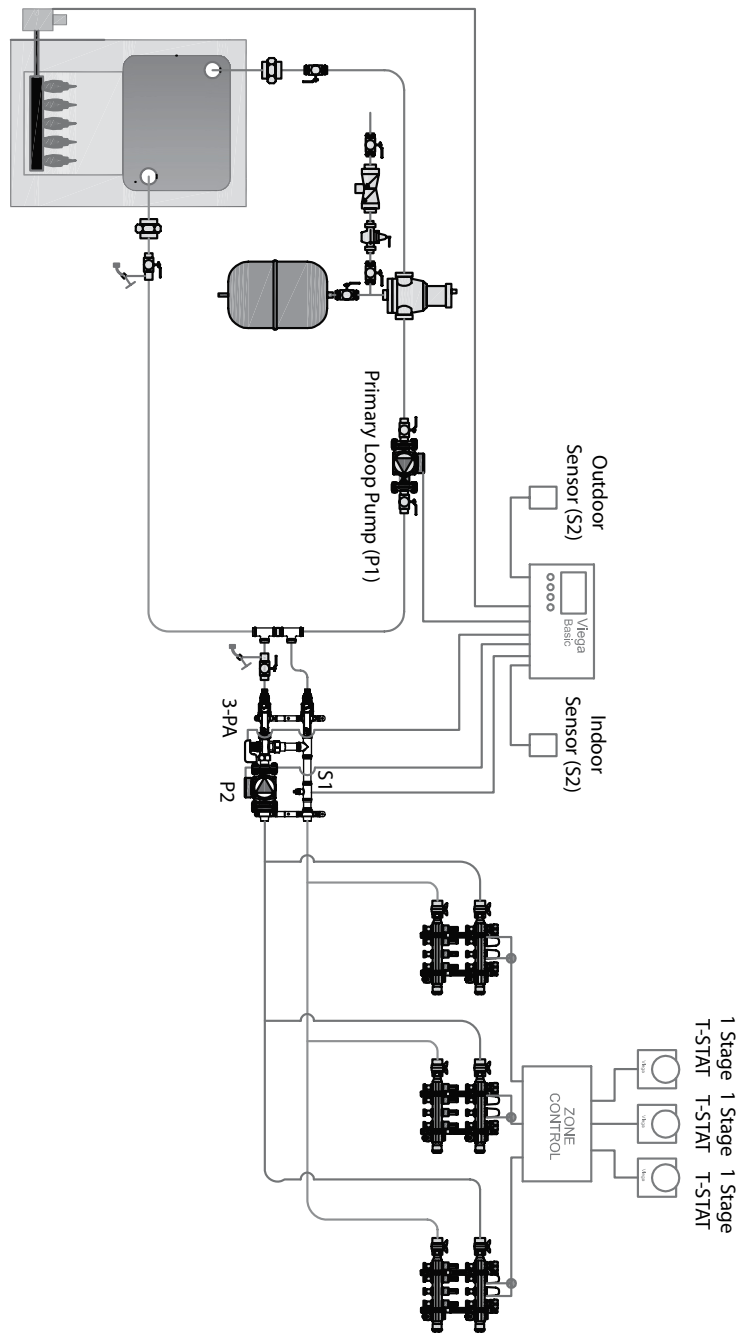

Viega... The global leader in plumbing, heating and pipe joining systems

301 N. Main, 9th Floor • Wichita, KS 67202 • Ph: 800-976-9819 • Fax: 316-425-7618 • www.viega.com

©2011, ProPress®, FostaPEX®, Seapress®, MegaPress®, MegaPressG® and Viega® are registered trademarks of Viega GmbH & Co. PureFlow®, Smart Connect®, Climate Panel®, Climate Mat®, Climate Trak®, MANABLOC®, Radiant Wizard®, S-no-ice®, Snap Panel®, XL® and XL-C® are registered trademarks of Viega LLC. MiniBloc™, ProRadiant™, PolyAlloy™, SmartLoop™ and Zero Lead™ are trademarks of Viega LLC; GeoFusion™, ProPressG™ and ViegaPEX™ are trademarks of Viega GmbH & Co. KG.

Product Instructions

viega

Enhanced Mixing Station Wiring Schematic

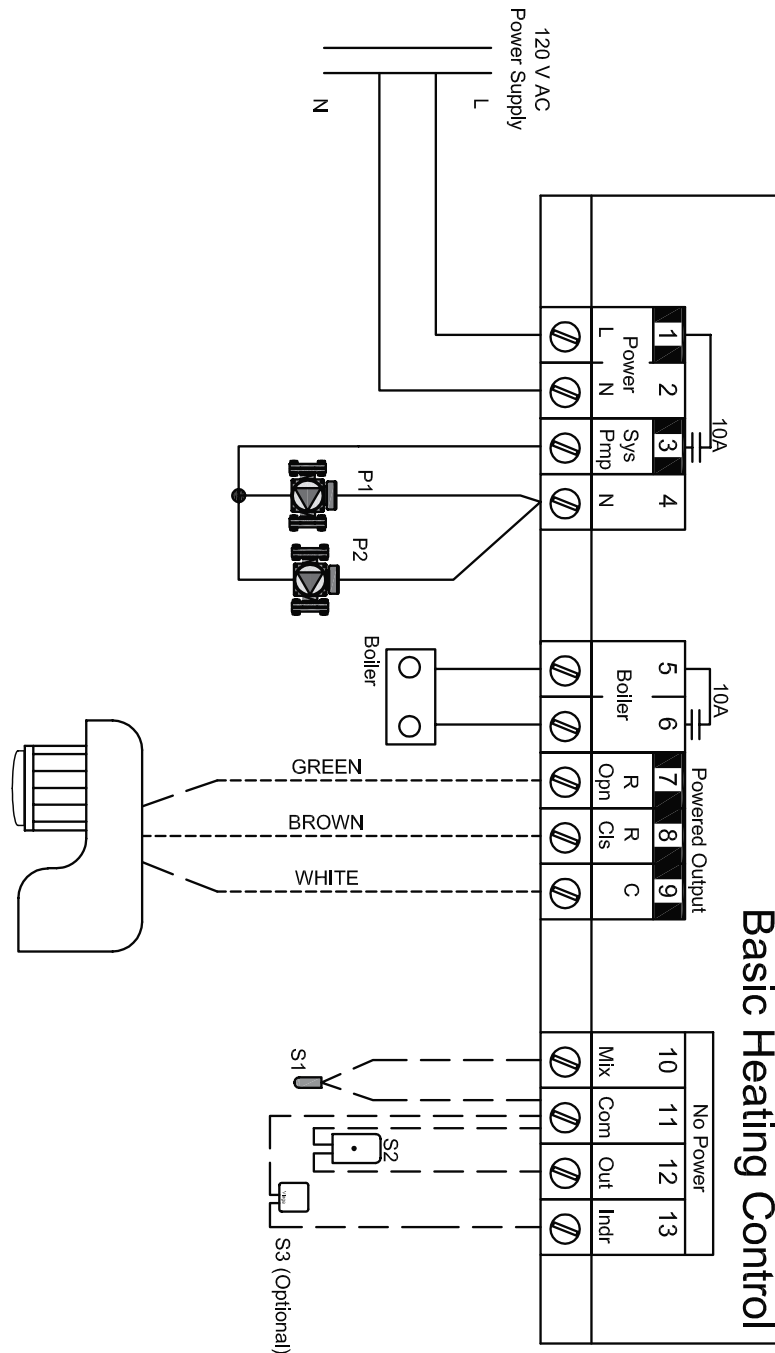

Viega... The global leader in plumbing, heating and pipe joining systems

301 N. Main, 9th Floor • Wichita, KS 67202 • Ph: 800-976-9819 • Fax: 316-425-7618 • www.viega.com

©2011, ProPress®, FostaPEX®, Seapress®, MegaPress®, MegaPressG® and Viega® are registered trademarks of Viega GmbH & Co. PureFlow®, Smart Connect®, Climate Panel®, Climate Mat®, Climate Trak®, MANABLOC®, Radiant Wizard®, S-no-ice®, Snap Panel®, XL® and XL-C® are registered trademarks of Viega LLC. MiniBloc™, ProRadiant™, PolyAlloy™, SmartLoop™ and Zero Lead™ are trademarks of Viega LLC; GeoFusion™, ProPressG™ and ViegaPEX™ are trademarks of Viega GmbH & Co. KG.