

Product Instructions

viega

Copper Manifold End Cap

Applications

Copper Manifold End Caps have two F NPT adapters: 1/2" for draw-off (purge valves), and 1/8" for automatic air vents (bottle vents). Made of Type "L" copper.

Features

- 1/2" F NPT for Draw-Off (purge valve)
- 1/8" F NPT for Automatic Vent (bottle vent)
- Type "L" Copper Tube

Specifications

Copper:	Type "L" ASTM B88
Min Temp:	36°F
Max Temp:	250°F
Max pressure:	200 psi
Maximum Glycol Mix:	50%

Installation

1. Cut copper tubing cleanly with a tube cutter.
2. Ream and debur cut copper tubing.
3. Clean the inside of the Copper End Cap and copper tubing (fitting brush / emery cloth). The copper should shine.
4. Brush an even layer of flux over the copper tubing and Copper End Cap.
5. Push the joint together until the copper tube seats full depth. Wipe off excess flux.
6. Heat the joint with a torch, moving the flame back and forth to heat it evenly. Hold the solder against the joint on the side opposite the flame until it melts and flows into the joint. Touch the solder 360° around the tubing. The joint should appear full on all sides. The solder hardens as it cools.
7. Avoid overfeeding the joint with solder. The amount of solder required is equivalent to the diameter of copper tubing being soldered.
8. Wrap Teflon Tape around the draw-off (purge valve) and the automatic air vent (bottle vent) the same direction as if tightening into the roll of Teflon Tape. Apply a small amount of thread sealant to the Teflon tape layer and hold the F NPT adapter while threading in the purge valve.

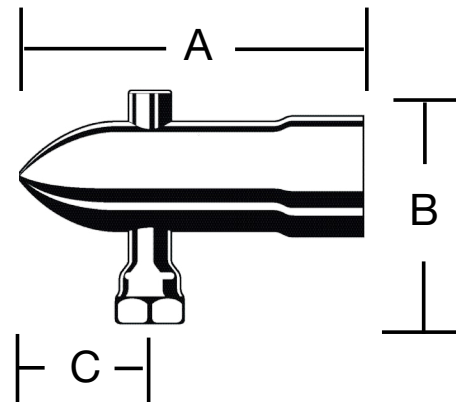
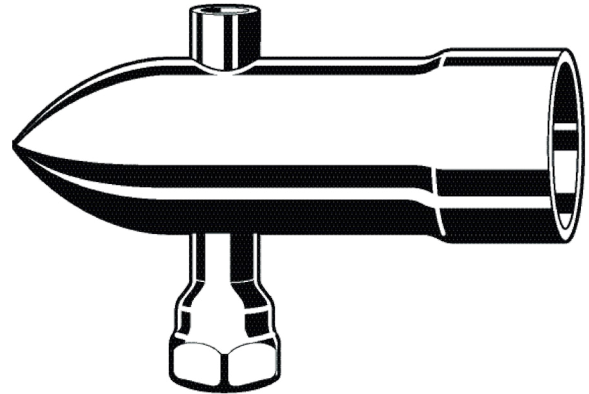

Stock Code	Size	A	B	C
17144	1"	5.0	3.1	2.0
17125	1-1/2"	5.25	3.3	2.0
17106	2"	5.4	4.0	2.8

Viega... The global leader in plumbing, heating and pipe joining systems

301 N. Main, 9th Floor • Wichita, KS 67202 • Ph: 800-976-9819 • Fax: 316-425-7618 • www.viega.com

©2011, ProPress®, FostaPEX®, Seapress®, MegaPress®, MegaPressG® and Viega® are registered trademarks of Viega GmbH & Co. PureFlow®, Smart Connect®, Climate Panel®, Climate Mat®, Climate Trak®, MANABLOC®, Radiant Wizard®, S-no-Ice®, Snap Panel®, XL® and XL-C® are registered trademarks of Viega LLC. MiniBloc®, ProRadiant®, PolyAlloy®, SmartLoop® and Zero Lead® are trademarks of Viega LLC; GeoFusion™, ProPressG™ and ViegaPEX™ are trademarks of Viega GmbH & Co. KG.